

PRO-CUT™ 55

For use with machine code numbers **Below 11000**

Safety Depends on You

Lincoln arc welding and cutting equipment is designed and built with safety in mind. However, your overall safety can be increased by proper installation . . . and thoughtful operation on your part. **DO NOT INSTALL, OPERATE OR REPAIR THIS EQUIPMENT WITHOUT READING THIS MANUAL AND THE SAFETY PRECAUTIONS CONTAINED THROUGHOUT.** And, most importantly, think before you act and be careful.

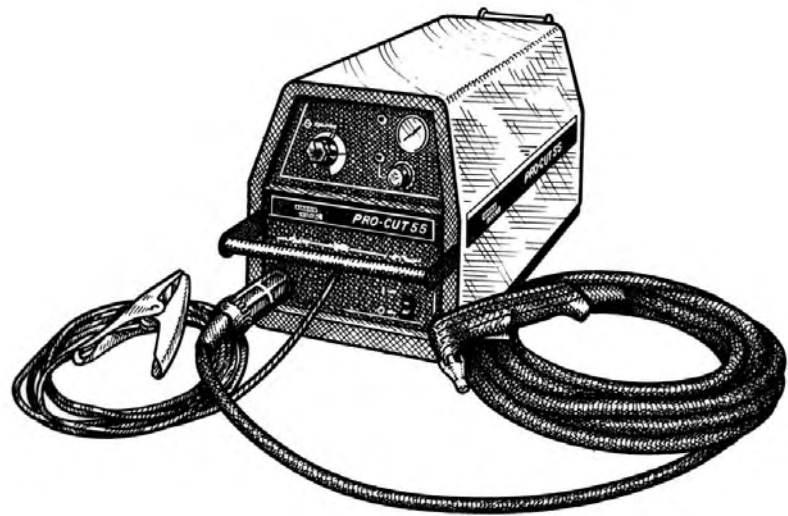

SERVICE MANUAL

LINCOLN®
ELECTRIC

Copyright © 2005 Lincoln Global Inc.

- World's Leader in Welding and Cutting Products •
- Sales and Service through Subsidiaries and Distributors Worldwide •

Cleveland, Ohio 44117-1199 U.S.A. TEL: 216.481.8100 FAX: 216.486.1751 WEB SITE: www.lincolnelectric.com

⚠ WARNING

PLASMA CUTTING or GOUGING can be hazardous.

PROTECT YOURSELF AND OTHERS FROM POSSIBLE SERIOUS INJURY OR DEATH. KEEP CHILDREN AWAY. PACEMAKER WEARERS SHOULD CONSULT WITH THEIR DOCTOR BEFORE OPERATING.

Read and understand the following safety highlights. For additional safety information it is strongly recommended that you purchase a copy of "Safety in Welding & Cutting - ANSI Standard Z49.1" from the American Welding Society, P.O. Box 351040, Miami, Florida 33135 or CSA Standard W117.2.

BE SURE THAT ALL INSTALLATION, OPERATION, MAINTENANCE, AND REPAIR PROCEDURES ARE PERFORMED ONLY BY QUALIFIED INDIVIDUALS.



ELECTRIC SHOCK can kill.

1.a. The electrode and work (or ground) circuits are electrically "hot" when the power source is on. Do not touch these "hot" parts with your bare skin or wet clothing. Wear dry, hole-free gloves to insulate hands.

- 1.b. When the power source is operating voltages in excess of 250 volts are produced. This creates the potential for serious electrical shock - potentially even fatal.
- 1.c. Insulate yourself from work and ground using dry insulation. When cutting or gouging in damp locations, on metal framework such as floors, gratings or scaffolds and when in positions such as sitting or lying, make certain the insulation is large enough to cover your full area of physical contact with work and ground.
- 1.d. Always be sure the work cable makes a good electrical connection with the metal being cut or gouged. The connection should be as close as possible to the area being cut or gouged.
- 1.e. Ground the work or metal to be cut or gouged to a good electrical (earth) ground.
- 1.f. Maintain the plasma torch, cable and work clamp in good, safe operating condition. Replace damaged insulation.
- 1.g. Never dip the torch in water for cooling or plasma cut or gouge in or under water.
- 1.h. When working above floor level, protect yourself from a fall should you get a shock.
- 1.i. Operate the pilot arc with caution. The pilot arc is capable of burning the operator, others or even piercing safety clothing.
- 1.j. Also see Items 4c and 6.

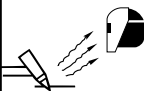

ARC RAYS can burn.

2.a. Use safety glasses and a shield with the proper filter and cover plates to protect your eyes from sparks and the rays of the arc when performing or observing plasma arc cutting or gouging. Glasses, headshield and filter lens should conform to ANSI Z87.1 standards.

- 2.b. Use suitable clothing including gloves made from durable flame-resistant material to protect your skin and that of your helpers from the arc rays.
- 2.c. Protect other nearby personnel with suitable non-flammable screening and/or warn them not to watch the arc nor expose themselves to the arc rays or to hot spatter or metal.



FUMES AND GASES can be dangerous.

3.a. Plasma cutting or gouging may produce fumes and gases hazardous to health. Avoid breathing these fumes and gases. When cutting or gouging, keep your head out of the fumes. Use enough ventilation and/or exhaust at the arc to keep fumes and gases away from the breathing

zone. **When cutting or gouging on lead or cadmium plated steel and other metals or coatings which produce highly toxic fumes keep exposure as low as possible and below Threshold Limit Values (TLV) using local exhaust or mechanical ventilation. In confined spaces or in some circumstances, outdoors, a respirator may be required. Additional precautions are also required when welding on galvanized steel.**

- 3.b. Do not use plasma arc cutting or gouging in locations near chlorinated hydrocarbon vapors coming from degreasing, cleaning or spraying operations. The heat and rays of the arc can react with solvent vapors to form phosgene, a highly toxic gas, and other irritating products.
- 3.c. Gases used for plasma cutting and gouging can displace air and cause injury or death. Always use enough ventilation, especially in confined areas, to insure breathing air is safe.
- 3.d. Read and understand the manufacturer's instructions for this equipment and the consumables to be used, including the material safety data sheet (MSDS) and follow your employer's safety practices.



CUTTING SPARKS can cause fire or explosion.

4.a. Remove fire hazards from the plasma cutting or gouging area. If this is not possible, cover them to prevent the cutting or gouging sparks from starting a fire. Remember that welding sparks and hot materials from plasma cutting or gouging can easily go through small cracks and openings to adjacent areas. Avoid cutting or gouging near hydraulic lines. Have a fire extinguisher readily available.

- 4.b. Where compressed gases are to be used at the job site, special precautions should be used to prevent hazardous situations. Refer to "Safety in Welding and Cutting" (ANSI Standard Z49.1) and the operating information for the equipment being used.
- 4.c. When not cutting or gouging, make certain no part of the electrode circuit is touching the work or ground. Accidental contact can cause overheating and create a fire hazard.
- 4.d. Do not cut or gouge tanks, drums or containers until the proper steps have been taken to insure that such procedures will not cause flammable or toxic vapors from substances inside. They can cause an explosion even though they have been "cleaned." For information purchase "Recommended Safe Practices for the Preparation for Welding and Cutting of Containers and Piping That Have Held Hazardous Substances", AWS F4.1 from the American Welding Society (see address above).
- 4.e. Vent hollow castings or containers before heating, cutting or gouging. They may explode.
- 4.f. Do not fuel engine driven equipment near area where plasma cutting or gouging.

- 4.g. Sparks and spatter are thrown from the plasma arc. Wear safety glasses, ear protection and oil free protective garments such as leather gloves, heavy shirt, cuffless trousers, high shoes and a cap over your hair. Wear ear plugs when cutting or gouging out of position or in confined places. Always wear safety glasses with side shields when in a cutting or gouging area.
- 4.h. Connect the work cable to the work as close to the cutting or gouging area as practical. Work cables connected to the building framework or other locations away from the cutting or gouging area increase the possibility of the current passing through lifting chains, crane cables or other alternate circuits. This can create fire hazards or overheat lifting chains or cables until they fail.



CYLINDER may explode if damaged.

5.a. Use only compressed gas cylinders containing the correct gas for the process used and properly operating regulators designed for the gas and pressure used. All hoses, fittings, etc.

should be suitable for the application and maintained in good condition.

- 5.b. Always keep cylinders in an upright position securely chained to an undercarriage or fixed support.
- 5.c. Cylinders should be located:
- Away from areas where they may be struck or subjected to physical damage.
 - A safe distance from plasma cutting or gouging, arc welding operations and any other source of heat, sparks, or flame.
- 5.d. Never allow any part of the electrode, torch or any other electrically "hot" parts to touch a cylinder.
- 5.e. Keep your head and face away from the cylinder valve outlet when opening the cylinder valve.
- 5.f. Valve protection caps should always be in place and hand tight except when the cylinder is in use or connected for use.
- 5.g. Read and follow the instructions on compressed gas cylinders, associated equipment, and CGA publication P-1, "Precautions for Safe Handling of Compressed Gases in Cylinders," available from the Compressed Gas Association 1235 Jefferson Davis Highway, Arlington, VA 22202.



FOR ELECTRICALLY powered equipment.

6.a. Turn off input power using the disconnect switch at the fuse box before working on the equipment.

- 6.b. Install equipment in accordance with the U.S. National Electrical Code, all local codes and the manufacturer's recommendations.
- 6.c. Ground the equipment in accordance with the U.S. National Electrical Code and the manufacturer's recommendations.



PLASMA ARC can injure.

7.a. Keep your body away from nozzle and plasma arc.

7.b. Operate the pilot arc with caution. The pilot arc is capable of burning the operator, others or even piercing safety clothing.



ELECTRIC AND MAGNETIC FIELDS may be dangerous

8.a. Electric current flowing through any conductor causes localized Electric and Magnetic Fields (EMF). Cutting or gouging current creates EMF fields around torch cables and cutting machines.

8.b. EMF fields may interfere with some pacemakers, so operators having a pacemaker should consult their physician before cutting or gouging.

- 8.c. Exposure to EMF fields during cutting or gouging may have other health effects which are now not known.
- 8.d. All operators should use the following procedures in order to minimize exposure to EMF fields from the cutting or gouging circuit:
- 8.d.1. Route the torch and work cables together - Secure them with tape when possible.
 - 8.d.2. Never coil the torch cable around your body.
 - 8.d.3. Do not place your body between the torch and work cables. If the torch cable is on your right side, the work cable should also be on your right side.
 - 8.d.4. Connect the work cable to the workpiece as close as possible to the area being cut or gouged.
 - 8.d.5. Do not work next to cutting power source.

Apr. '93

Return to Master TOC

Return to Master TOC

Return to Master TOC

Return to Master TOC

PRO-CUT 55



MASTER TABLE OF CONTENTS FOR ALL SECTIONS

	Page
Safety	i-iii
Installation	Section A
Operation	Section B
Accessories	Section C
Maintenance	Section D
Theory of Operation	Section E
Troubleshooting and Repair	Section F
Safety Precautions	F-2
How to Use Troubleshooting Guide.....	F-2
Troubleshooting Guide	F-4
Test Procedures	F-14
Replacement Procedures	F-50
Electrical Diagrams	Section G
Parts Manual	P309 Series & P210-K

TABLE OF CONTENTS - INSTALLATION SECTION -

Installation

Technical Specifications	A-2
Safety Precautions.....	A-4
Select Suitable Location.....	A-4
Stacking	A-4
Lifting and Moving.....	A-4
Tilting	A-4
High Frequency Interference Protection.....	A-4
Input Electrical Connections.....	A-5
Ground Connection	A-5
Input Power Cord Connector Installation.....	A-5
Input Wire and Fuse Size	A-5
Reconnect Procedure.....	A-6
Gas Input Connections.....	A-7
Output Connections	A-8
Torch Connection	A-8

Return to Master TOC

Return to Master TOC

Return to Master TOC

Return to Master TOC

INSTALLATION

TECHNICAL SPECIFICATIONS - PRO-CUT 55

INPUT RATINGS		
<p><u>Single Phase Input Voltage and Hertz</u></p> <p>208/1/60 230/1/60 460/1/60</p> <p>208/1/60 230/1/60 460/1/60</p>	<p><u>Input Currents</u></p> <p>60 55 30</p> <p>44 40 23</p>	<p><u>Rated Output Amps</u></p> <p>55 55 55</p> <p>40 40 40</p>
<p><u>Three Phase Input Voltage and Hertz</u></p> <p>208/3/60 230/3/60 460/3/60</p> <p>208/3/60 230/3/60 460/3/60</p>	<p><u>Input Currents</u></p> <p>31 28 17</p> <p>23 21 15</p>	<p><u>Rated Output Amps</u></p> <p>55 55 55</p> <p>40 40 40</p>
IDLE CURRENT AND WATTS		
230/1/60	0.42 Amps	98 Watts
RATED OUTPUT		
<p><u>Duty Cycle</u></p> <p>50% 100%</p>	<p><u>Rated Output Amps</u></p> <p>55 40</p>	
OUTPUT		
<p><u>Current Range</u></p> <p>25 - 55 Amps</p>	<p><u>Open Circuit Voltage</u></p> <p>335VDC Maximum</p>	<p><u>Pilot Current</u></p> <p>18 Amps @ 100% Duty Cycle</p>

PRO-CUT 55



Return to Section TOC

Return to Master TOC

INSTALLATION

TECHNICAL SPECIFICATIONS (Cont'd) - PRO-CUT 55

GAS REQUIREMENTS

Required Gas Flow Rate

70 PSI @ 360 SCHF
(4.8 Bar. @ 10160 LHR)
(6 CFM)

Required Gas Inlet Pressure

80 to 150 PSI
(5.4 Bar. to 10.2 Bar.)

RECOMMENDED INPUT WIRE AND FUSE SIZES

For all plasma cutting applications based on U.S. National Electrical Code
Ambient Temperature 30°C or Less

<u>AC Input Voltage at 60 Hertz</u>	<u>Fuse (Super Lag) Circuit Breaker (Delay Type)</u>	<u>Type 75°C Copper Wire in Conduit AWG (IEC) Sizes</u>	
230VAC Single Phase 460VAC Single Phase	70 Amps 40 Amps	2 Input Supply Wires #8 (8.4mm ²) #8 (8.4mm ²)	1 Ground Wire #10 (5.3mm ²) #10 (.3mm ²)
230VAC Three Phase 460VAC Three Phase	40 Amps 20 Amps	#10 (5.3mm ²) #10 (5.3mm ²)	#10 (5.3mm ²) #10 (5.3mm ²)

PHYSICAL DIMENSIONS

<u>Height</u>	<u>Width</u>	<u>Depth</u>	<u>Weight with Torch Cable</u>
12.6 Inches 320 mm	11.0 Inches 280 mm	26.0 Inches 660 mm	70 lbs. (32 kg.) (25 ft. cable) 85 lbs. (39 kg.) (50 ft. cable)

PRO-CUT 55



Return to Section TOC
Return to Master TOC

Return to Section TOC
Return to Master TOC

Return to Section TOC
Return to Master TOC

Return to Section TOC
Return to Master TOC

Read this entire installation section before you start installation.

SAFETY PRECAUTIONS

⚠ WARNING



ELECTRIC SHOCK can kill.

- Turn the input power OFF at the disconnect switch or fuse box and discharge input capacitors before working inside the equipment.
- Do not touch electrically hot parts or electrodes with your skin or wet clothing.
- Always connect the 55 grounding terminal (located on the side of the Case Back Assembly) to a good electrical earth ground.
- Always wear dry, insulating gloves.
- Turn the 55 Power Switch OFF when connecting power cord to input power.

Only qualified personnel should install, use, or service this equipment.

SELECT SUITABLE LOCATION

Place the Pro-Cut 55 where clean cool air can freely circulate in through the rear louvers and out through the front/bottom opening. Dirt, dust or any foreign material that can be drawn into the machine should be kept at a minimum. Failure to observe these precautions can result in excessive operating temperatures and nuisance shutdown of the machine.

A source of clean, dry air or nitrogen must be supplied to the Pro-Cut 55. Oil in the air is a severe problem and must be avoided. The supply pressure must be between 80 and 150 psi. The flow rate is approximately 6.0 cfm (170 l/min.). Failure to observe these precautions could result in excessive operating temperatures or damage to the torch.

STACKING

The Pro-Cut 55 cannot be stacked.

LIFTING AND MOVING

⚠ WARNING



FALLING EQUIPMENT can cause injury.

- Do not use the pull handle on the optional undercarriage, if installed, to lift the machine. This handle is not designed to support the full weight of the machine. Using it to lift the machine could cause personal injury or damage to the machine.
- Either the front or rear handles or both may be used to lift or move the machine.

TILTING

The Pro-Cut 55 must be placed on a stable, level surface so it will not topple over.

HIGH FREQUENCY INTERFERENCE PROTECTION

The Pro-Cut 55 employs a touch start mechanism for arc initiation. This eliminates high frequency emissions from the machine as compared with spark gap and solid state type high frequency generators. Keep in mind, though, that these machines may be used in an environment where other high frequency generating machines are operating. By taking the following steps, you can minimize high frequency interference.

- Make sure the power supply chassis is connected to a good earth ground. The work terminal ground does NOT ground the machine frame.
- Keep the work ground clamp isolated from other work clamps that have high frequency.
- If the ground clamp cannot be isolated, then keep the clamp as far as possible from other work clamp connections.
- When the machine is enclosed in a metal building, several good earth driven electrical grounds around the periphery of the building are recommended.

Failure to observe these recommended installation procedures may cause improper function of the Pro-Cut or possibly even damage the control system or power supply components.

PRO-CUT 55



INSTALLATION

INPUT CONNECTIONS

⚠ WARNING

ELECTRIC SHOCK can kill.



- Have a qualified electrician install and service this equipment.
- Turn the input power off at the fuse box before working on this equipment.

- Do not touch electrically hot parts.

Before installing the machine, check that input supply voltage, phase, and frequency are the same as the machine's voltage, phase, and frequency as specified on the machine's rating plate. See Figure A.1.

FIGURE A.1 – RATING PLATE LOCATION

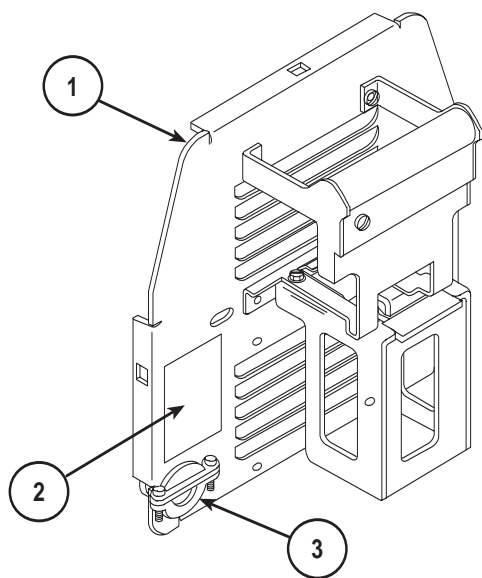

1. CASE BACK
2. RATING PLATE
3. POWER CORD CONNECTOR WITH STRAIN RELIEF

The Pro-Cut 55 should be connected only by a qualified electrician. Installation should be made in accordance with the U.S. National Electrical Code, all local codes, and the information detailed below.

GROUND CONNECTION

The frame of the Pro-Cut 55 must be properly grounded. A ground terminal marked with the symbol \perp is mounted on the case bottom directly behind the input power switch for this purpose. The ground lead of the input power cord that is attached to the machine must be connected to this ground terminal. See the National Electric Code for details on proper grounding methods. Install in accordance with all local and national electrical codes.

INPUT POWER CORD CONNECTOR INSTALLATION

The Pro-Cut 55 is supplied with one 11 foot (3.35m) #8 AWG 3 lead input power cord already connected to the machine. A cord connector provides a strain relief for the input power cord as it passes through the left rear access hole. The cord connector is designed for a cord diameter of .40 - 1.03 in (10.2 - 26.2mm) if it becomes necessary to install a different input cord. See Figure A.1.

For three phase connection: Replace the input power cord with a #10 AWG 4 lead cable.

Connect the leads of the cable to a fused power panel. Make sure the green lead is connected to the panel and the panel is connected to a good earth ground.

Install in accordance with all local and national electric codes.

INPUT WIRE AND FUSE SIZE

Fuse the input circuit with the super lag fuses or delay type circuit breakers recommended on the **Technical Specifications** page. Choose an input and grounding wire size according to local or national codes; also see the **Technical Specifications** page. Using fuses or circuit breakers smaller than recommended may result in “nuisance” shut-offs from inrush currents, even if you are not cutting at high currents.

PRO-CUT 55



RECONNECT PROCEDURE

When received directly from the factory, the machines are internally connected for 230 VAC. Reconnection will be necessary if a higher input voltage is used. To reconnect the Pro-Cut to 460 VAC or to connect back to 230 VAC, follow the directions as outlined below. Follow this procedure **ONLY** while the Pro-Cut is disconnected from the input power.

⚠ CAUTION

Failure to follow these instructions can cause immediate failure of components in the welder.

1. Open the access door on the back of the machine. Connection instructions are also included on the inside of the door.
2. For 230: Position the large switch to 200-230. See Figure A.2.
For 460: Position the large switch to 380-460. See Figure A-2.
3. Move the "A" lead to the appropriate terminal.

FIGURE A.2 – RECONNECTION DIAGRAM

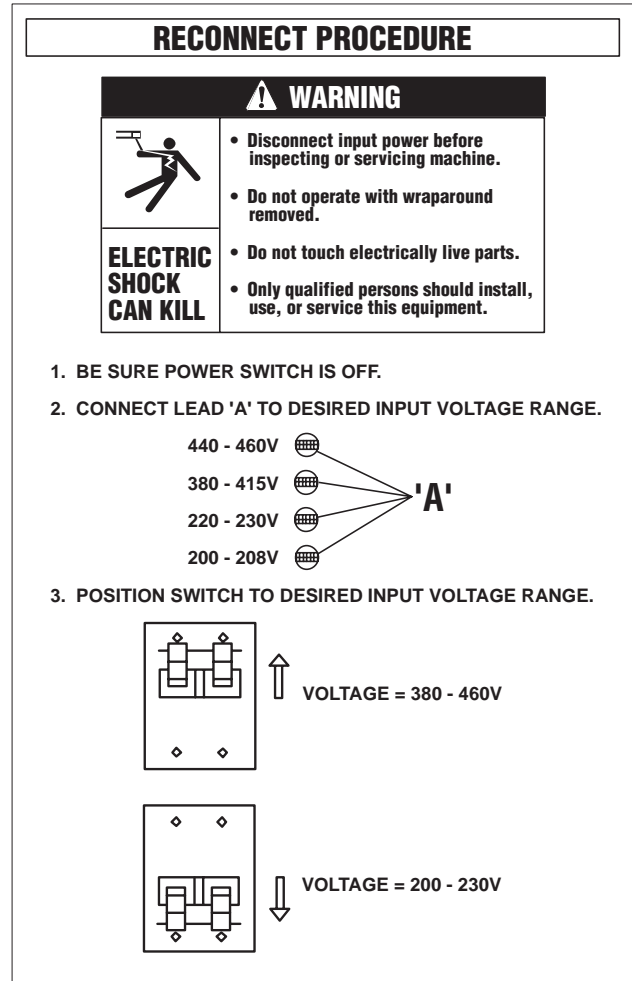

INSTALLATION

GAS INPUT CONNECTIONS

Supply the Pro-Cut 55 with clean compressed air or nitrogen.

- Supply pressure must be between 80 psi and 150 psi.
- Flow rate should be approximately 6.0 cfm (170 l/min.).

NOTE: Oil in the air supply to the Pro-Cut 55 can cause severe problems. Use only a clean air supply.

- Connect the gas supply to the Pro-Cut 55's pneumatic nipple at the air filter. See Figure A.3.
- Compressed gas should be supplied to the fitting connection mounted on the filter at the rear of the machine. If necessary, this fitting can be removed allowing plumbing access through the 1/4 in. (6.4mm) NPT input port on the filter body.

⚠ WARNING

CYLINDER could explode if damaged.

- Keep cylinder upright and chained to a fixed support.

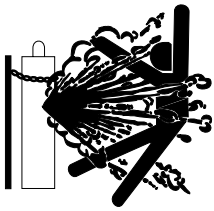

- Keep cylinder away from areas where it could be damaged.
- Never lift machine with cylinder attached.
- Never allow the cutting torch to touch the cylinder.
- Keep cylinder away from live electrical parts.

- Maximum inlet pressure 150 psi.

NOTE: When using nitrogen gas from a cylinder, the cylinder must have a pressure regulator.

- Maximum psi from nitrogen gas cylinder to Pro-Cut 55 regulator should never exceed 150 psi.
- Install a hose between the nitrogen gas cylinder regulator and the Pro-Cut 55 gas inlet.

FIGURE A.3 - COMPRESSED GAS CONNECTION

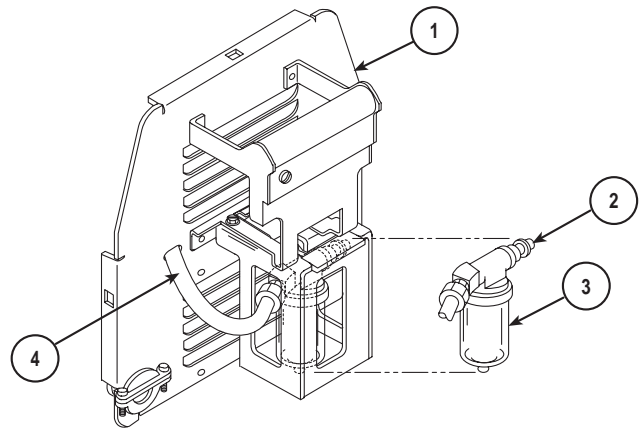

1. CASE BACK
2. PNEUMATIC NIPPLE
3. AIR FILTER
4. FLEX TUBE (TO REGULATOR INSIDE MACHINE)

PRO-CUT 55



Return to Section TOC
Return to Master TOC

INSTALLATION

OUTPUT CONNECTIONS

TORCH CONNECTION

The Pro-Cut 55 is supplied from the factory with a PCT 80 cutting torch. Additional cutting torches can be ordered from the K1571 series. Hand-held and mechanized torches come with 25 or 50 foot cables.

All torches are connected to the Pro-Cut with a quick connect at the case front for easy change over. See Figure A-4.

For more information on the torch and its components, refer to the PCT 80 Operators Manual (IM588).

FIGURE A.4 - TORCH CONNECTION AT CASE FRONT

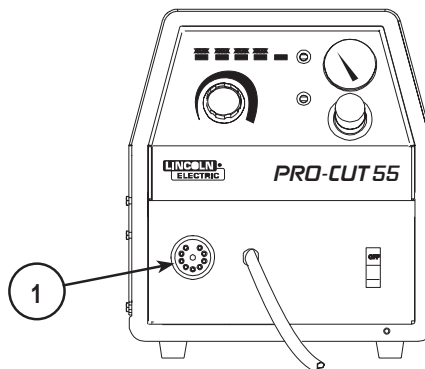

1. TORCH CONNECTION

Return to Section TOC
 Return to Master TOC
 Return to Section TOC
 Return to Master TOC
 Return to Section TOC
 Return to Master TOC
 Return to Section TOC
 Return to Master TOC

PRO-CUT 55



TABLE OF CONTENTS - OPERATION SECTION -

Operation	Section B
Safety Instructions	B-2
General Description	B-3
Recommended Process and Equipment.....	B-3
Operational Features and Controls	B-3
Design Features and Advantages.....	B-3
Cutting Capability	B-4
Consumable Life.....	B-4
Limitations.....	B-4
Controls and Settings.....	B-5
Pilot Arc Considerations	B-5
Cutting Operation	B-5
User Responsibility	B-7
Preheat Temperature for Plasma Cutting	B-7
Procedure Recommendations	B-7
General	B-7
Thin Gauge Sheet Metal	B-7
Thick Sections of Metal.....	B-8
Suggestions for Extra Utility From the Pro-Cut System	B-8

Return to Master TOC

Return to Master TOC

Return to Master TOC

Return to Master TOC

OPERATING INSTRUCTIONS

Read and understand this entire section of operating instructions before operating the machine.

SAFETY INSTRUCTIONS

WARNING



ELECTRIC SHOCK can kill.

- Do not touch electrically live parts or electrodes with your skin or wet clothing.
- Insulate yourself from the work and ground.
- Always wear dry, insulating gloves.



FUMES AND GASES can be dangerous.

- Keep your head out of fumes.
- Use ventilation or exhaust to remove fumes from breathing zone.



CUTTING SPARKS can cause fire or explosion.

- Keep flammable material away.
- Do not cut containers that have held combustibles.



ARC RAYS can burn.

- Wear eye, ear, and body protection.



PLASMA ARC can injure.

- Keep your body away from nozzle and plasma arc.
- Operate the pilot arc with caution. The pilot arc is capable of burning the operator, others, or even piercing safety clothing.

Observe additional Safety Guidelines detailed in the beginning of this manual.

OPERATION

GENERAL DESCRIPTION

The Pro-Cut 55 is an inverter based constant current, continuous control plasma cutting power source. It provides superior and reliable starting characteristics, cutting visibility and arc stability. When cutting expanded metal, the Pro-Cut 55 out-performs the competition due to its quick, clean response to arc transfers. The power supply design provides high transfer-to-cut distances, which makes pierce cutting more reliable with less nozzle wear. The control system has a safety mechanism to insure that the nozzle and electrode are in place before cutting or gouging. This is extremely important due to the high voltages involved.

The Pro-Cut 55 comes standard with an air regulator, coarse air filter, and pressure gauge. The machine also comes with an 11 foot (3.35m) input power cord. There are four different torch and cable systems to choose from: hand-held torch with 25 foot (7.62m) or 50 foot (15.24m) cable, machine and robotic torch both with 25 foot (7.62m) and 50 foot (15.24m) cable. Consumables are included with each Pro-Cut purchase so that cutting can begin right out of the box. Consumables can also be ordered as individual packages. An undercarriage kit can be ordered separately.

The Pro-Cut 55 initiates the plasma arc with a simple, yet reliable, touch-start mechanism. This system eliminates many of the failure problems associated with high-frequency start systems. The Pro-Cut 55 is capable of cutting with nitrogen or air.

The Pro-Cut 55 is controlled by a microprocessor-based control board. The machine performs rudimentary self troubleshooting when powered up, which aids in field servicing.

RECOMMENDED PROCESSES AND EQUIPMENT

The Pro-Cut 55 is capable of all cutting and gouging applications within its output capacity of 25 to 55 amps. These applications include thin gage sheet metal and expanded metal.

OPERATIONAL FEATURES AND CONTROLS

The Pro-Cut 55 comes with an ON/OFF POWER SWITCH, OUTPUT CURRENT CONTROL, PURGE BUTTON, STATUS INDICATORS and a SAFETY RESET BUTTON. See **Figure B.2** and related discussion.

DESIGN FEATURES AND ADVANTAGES

The microprocessor controlled Pro-Cut 55 design makes plasma cutting and gouging tasks uncomplicated. This list of design features and advantages will help you understand the machine's total capabilities so that you can get maximum use from your machine.

- Light weight and portable design for industrial use.
- Continuous control, 25 - 55 amps.
- Reliable touch start mechanism for plasma arc initiation.
- Unique microprocessor controlled starting sequence for safe and consistent starting.
- Rapid arc transfer for fast cutting of expanded metal.
- High transfer distance for ease of use.
- Input overvoltage protection.
- 3.0 second pilot arc.
- Purge momentary push button.
- Air regulator and pressure gauge located on the front of machine for convenience.
- "Parts-in-Place" mechanism to detect proper installation of consumables and torch.
- Automatic detection of faulty output control.
- In-line coarse air filter.
- Preflow/Postflow timing. Preflow is eliminated if arc is re-initiated in Postflow.
- Thermostatic Protection.
- Solid state overcurrent protection.
- Works with pure nitrogen for cutting nonferrous materials.
- Reconnectable for 230 VAC or 460 VAC inputs.
- Quick disconnect torch.
- Display indicators for machine status.
- Unique electrode and Vortech™ nozzle design for optimum cooling and long life.
- Swirl texture inside Vortech™ nozzle for better starting reliability and higher quality cuts.
- Unique drag cup design for durability and elimination of double arcing.

PRO-CUT 55



OPERATION

CUTTING CAPABILITY

The Pro-Cut 55 is rated at 55 amps, at 50% duty cycle on a 10 minute basis or 40 amps, at 100% duty cycle. If the duty cycle is exceeded, a thermal protector will shut off the output of the machine until it cools to the normal operating temperature.

Figure B.1 shows the cut capacity of the Pro-Cut 55 when cutting mild steel. The graph plots cut thickness vs. torch travel speed with a torch standoff of 0.15 in. (3.8mm).

Example: 0.25 material

<u>Amps</u>	<u>Speed (IPM)</u>
35	38
45	57
55	62

FIGURE B.1 – LINCOLN'S PRO-CUT 55 MILD STEEL CUT CAPACITY CHART

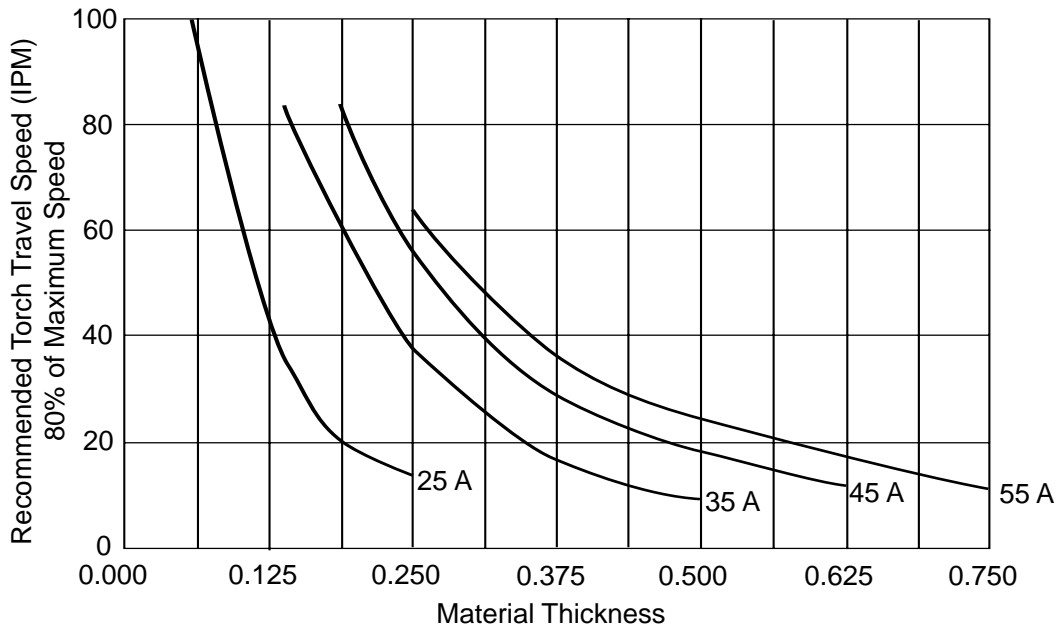

CONSUMABLE LIFE

The expected life for the Pro-Cut 55's electrode under normal operating conditions is approximately 320 starts/cuts. An erosion of .060 in. (1.5mm) is typical for end of electrode life. However, the electrode may last longer. A green and erratic arc will indicate definite electrode failure, and the electrode should be replaced immediately.

It is recommended that consumables be replaced in complete sets. (Example: Electrode and Nozzle). This will maximize the performance of the Pro-Cut 55 system.

LIMITATIONS

Do not exceed output current and duty cycle rating of machine. Do not use the Pro-Cut 55 for pipe thawing.

PRO-CUT 55



Return to Section TOC
Return to Master TOC
Return to Section TOC
Return to Master TOC
Return to Section TOC
Return to Master TOC
Return to Section TOC
Return to Master TOC

OPERATION

CONTROLS AND SETTINGS

FIGURE B.2 - CASE FRONT CONTROLS

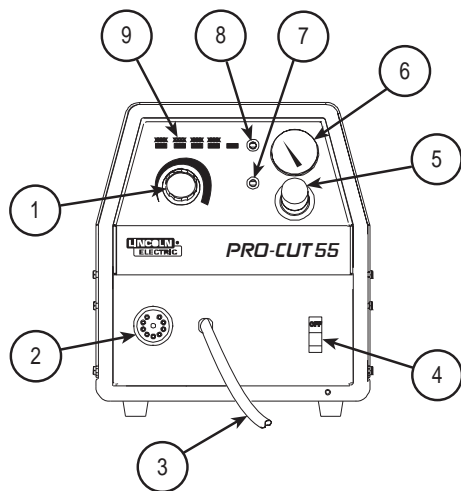

1. OUTPUT CURRENT CONTROL KNOB
2. TORCH CONNECTOR
3. WORK CABLE
4. INPUT POWER SWITCH
5. GAS REGULATOR KNOB
6. GAS REGULATOR GAUGE
7. GAS PURGE BUTTON
8. RESET BUTTON
9. STATUS (DISPLAY) BOARD INDICATORS

1. OUTPUT CURRENT CONTROL KNOB - Adjusts the amount of cutting current applied. Affects cutting speed, dross formation, cut width, heat zone and travel speed.
2. TORCH CONNECTOR - Quick-connect type coupling for the PCT 80 cutting torch.
3. WORK CABLE - Provides clamp and cable connection to workpiece.
4. ON/OFF POWER SWITCH - Turns machine on or off.
5. GAS REGULATOR KNOB - Adjusts compressed gas pressure delivered to the torch. Length of torch hose is an adjustment factor. Optimum setting is 70-75 psi. The gas purge button must be pressed in to set pressure.
6. GAS REGULATOR GAUGE - Provides gas pressure reading as set by the gas regulator knob.
7. GAS PURGE BUTTON - Used to check or set gas pressure. Push in and hold to check pressure, then continue to hold to set the pressure. Shuts off gas when released.
8. RESET BUTTON - Used to reset the machine following a safety circuit trip.
9. STATUS (DISPLAY) BOARD INDICATORS - Four lights indicating Power, Gas Low, Thermal and Safety.

PILOT ARC CONSIDERATIONS

The Pro-Cut has a smooth, continuous pilot arc. The pilot arc is only a means of transferring the arc to the workpiece for cutting. Repeated pilot arc starts, in rapid succession, is not recommended as these starts will generally reduce consumable life. Occasionally, the pilot arc may sputter or start intermittently. This is aggravated when the consumables are worn or the air pressure is too high. Always keep in mind that the pilot arc is designed to transfer the arc to the workpiece and not for numerous starts without cutting.

When the pilot arc is started, a slight impulse will be felt in the torch handle. This occurrence is normal and is the mechanism which starts the plasma arc. This impulse can also be used to help troubleshoot a "no start" condition.

CUTTING OPERATION

When preparing to cut or gouge, position the machine as close to the work as possible. Make sure you have all materials needed to complete the job and have taken all safety precautions. It is important to follow these operating steps each time you use the machine.

- Turn the machine's ON/OFF POWER SWITCH to the OFF position.
- Connect the air supply to the machine.
- Turn the main power and the machine power switch on.
 - The fan should start.
 - The pre-charge circuit will operate for 3 seconds, then the green "Power" status indicator should turn on.
 - If the "SAFETY" status indicator is lit, push the "Reset" button. If there is no problem, the status indicator will go off. If there is a problem, refer to **"STATUS INDICATOR"** in this section.
- Be sure that the work lead is clamped to the workpiece before cutting.
- Set the output current control knob for maximum current for high cutting speed and less dross formation per **Figure B.1**. Reduce the current, if desired, to reduce the kerf (cut) width, heat affected zone or travel speed as required.
- Push-in and hold the Purge button to check or set the gas pressure. Pull the pressure regulator cap out and turn it to set the pressure.
 - Adjust the gas regulator for 70 PSI for 25 foot (7.62m) torches or 75 PSI for 50 foot (15.24m) torches.
 - Release the Purge button.

PRO-CUT 55



OPERATION

- The gas will immediately turn off. The pressure gauge may show an increase in pressure after the air turns off, but this is normal. Do NOT reset the pressure while the air is NOT flowing.
- When ready to cut, place the torch near the work, make certain all safety precautions have been taken and pull the trigger.
 - The air will flow for a preflow time of 2 seconds and the pilot arc will start. (This is true unless the machine is in postflow, then the preflow time is skipped and the pilot arc will start immediately.)
 - The pilot arc will run for 3 seconds and shut off unless the arc is brought in contact with the work and the arc is transferred. Avoid excessive pilot arc time by transferring the arc to the workpiece quickly to improve parts life.
 - When the arc is brought within 1/4 in. (6.4mm) from the workpiece the arc will transfer, the current will ramp up to the setting on the control panel, and the cut can last indefinitely (or until the duty cycle of the Pro-Cut is exceeded). Do not touch the nozzle to the work when cutting. Damage to the consumables may result.
- Pierce the workpiece by slowly lowering the torch onto the metal at a 30° angle away from the operator. This will blow the dross away from the torch tip. Slowly rotate the torch to vertical position as the arc becomes deeper.

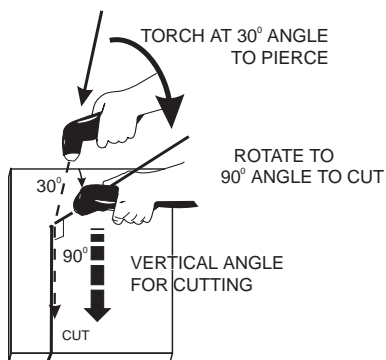

- Hold the nozzle standoff 1/8 in. (3.2mm) to 3/16 in. (4.7mm) above the workpiece during cutting. Do not let the torch nozzle touch the work or carry a long arc.
- Keep moving while cutting. Cut at a steady speed without pausing. Maintain the cutting speed so that the arc lag is 10° to 20° behind the travel direction.
- Use a 5° - 15° leading angle in the direction of the cut.
- Use the drag cup to maintain constant standoff for better cut quality and to protect the nozzle from spatter.
- Use the drag cup with a metal template to prevent nozzle double arcing.

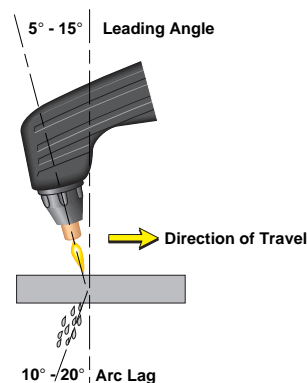

- Finish the cut to be made and release the trigger.
- When the trigger is released, the arc will stop.
 - The gas will continue to flow for 10 seconds of postflow. If the trigger is activated within this time period, the pilot arc will immediately restart.
- If the dross is difficult to remove, reduce the cutting speed. High speed dross is more difficult to remove than low speed dross.
- The right side of the cut is more square than the left as viewed along the direction of travel.
- Clean spatter and scale from the nozzle and drag cup frequently.
- **For gouging**, tilt the torch about 45° from the workpiece and hold the nozzle 1/8 in. (3.2mm) to 3/16" (4.7mm) above the workpiece.

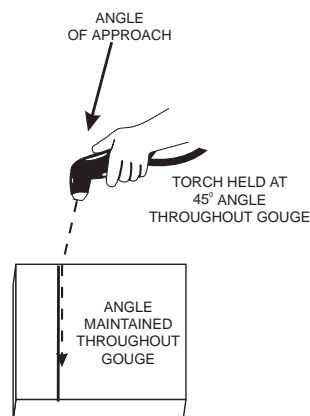

SAFETY STATUS INDICATOR

- If the "SAFETY" status indicators light at any time, check the following:
 - Check the assembly of the torch consumables. If they are not properly in place, the machine will not start. **Make sure that the shield cup is hand tight. Do not use pliers or over tighten.**

PRO-CUT 55



OPERATION

⚠ WARNING



ELECTRIC SHOCK can kill.

- Turn off machine at the disconnect switch on the front of the machine before tightening, cleaning or replacing consumables.

- Check the conditions of the inside of the nozzle. If debris has collected, rub the electrode on the inside bottom of the nozzle to remove any oxide layer that may have built up. Refer to **“Suggestions for Extra Utility from the Pro-Cut System.”**

- Check the condition of the electrode. If the end has a crater-like appearance, replace it along with the nozzle. The maximum wear depth of the electrode is approximately .062 in. (1.6mm). A green and erratic arc will indicate definite electrode failure. The electrode should be replaced immediately.

- Replace the nozzle when the orifice exit is eroded away or oval shaped.
- After the problem is found, or if there is nothing apparently wrong, reset the machine by pressing the "Reset" button. (It is possible for electrical noise to trip the safety circuit on rare occasions. This should not be a regular occurrence.)
- If the machine does not reset or continues to trip, consult the Troubleshooting Section.
- Use the proper cutting or gouging procedures referred to in “Procedure Recommendations” below.

USER RESPONSIBILITY

Because design, fabrication, erection and cutting variables affect results, the serviceability of a product or structure is the responsibility of the user. Variation such as plate chemistry, plate surface condition (oil, scale), plate thickness, preheat, quench, gas type, gas flow rate and equipment may produce results different from those expected. Some adjustments to procedures may be necessary to compensate for unique individual conditions. Test all procedures duplicating actual field conditions.

PREHEAT TEMPERATURE FOR PLASMA CUTTING

Preheat temperature control is not necessary in most applications when plasma arc cutting or gouging. Preheat temperature control may be necessary on high carbon alloy steels and heat treated aluminum for crack resistance and hardness control. Job conditions, prevailing codes, alloy level, and other considerations may also require preheat temperature control. The recommended minimum preheat temperature for plate thickness up to 1/2 in. (12.7mm) is 70°F (21.1°C). Higher temperatures may be used as required by the job conditions and/or prevailing codes. If cracking or excessive hardness occurs on the cut face, higher preheat temperature may be required.

PROCEDURE RECOMMENDATIONS

When properly used, plasma arc cutting or gouging is a very economical process. Improper use will result in a very high operating cost.

GENERAL - IN ALL CASES

- Follow safety precautions as printed throughout this manual and on the machine.

THIN GAUGE SHEET METAL

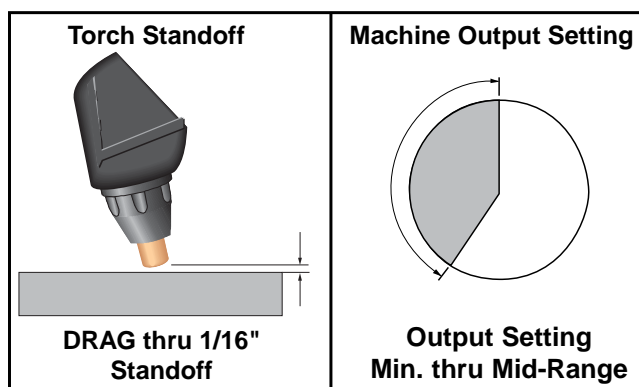

Output set below mid-range.

- The nozzle may be dragged on the metal surface, touching it lightly to the surface after piercing a hole. Current control should be set below the mid-range.
- Do not allow cable or body to contact hot surface.

PRO-CUT 55



OPERATION

THICK SECTIONS OF METAL

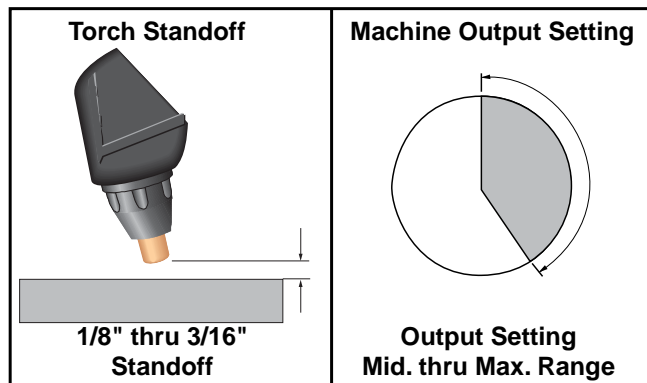

Output set above mid-range.

- The best quality and consumable life will be obtained by holding the torch off the surface about 3/16 in. (4.7mm). Too long an arc may compromise cut quality and consumable life. The nozzle should NOT be dragged on the work.
- Use of the S22151 Drag Cup will maintain the proper standoff. The only time not to use the drag cup when the output control is set above mid-range is in special, tight corners. Always hold at least a 1/8 in. (3.2mm) standoff in those situations.
- If piercing is required, slowly lower the torch at an angle of about 30° to blow the dross away from the torch tip and slowly rotate the torch to a vertical position as the arc becomes deeper. This process will blow a lot of molten metal and dross. Be careful! Blow the dross away from the torch, the operator and any flammable objects.
- Where possible, start the cut from the edge of the workpiece.
- Keep moving! A steady speed is necessary. Do not pause.
- Do not allow the torch cable or body to contact a hot surface.

SUGGESTIONS FOR EXTRA UTILITY FROM THE PRO-CUT SYSTEM

⚠ WARNING

ELECTRIC SHOCK can kill.



- Turn off machine at the disconnect switch on the front of the machine before tightening, cleaning or replacing consumables.

1. Occasionally an oxide layer may form over the tip of the electrode, creating an insulating barrier between the electrode and nozzle. This will result in the tripping of the Pro-Cut's safety circuit. When this happens, turn the power off, remove the nozzle and electrode and use the electrode to rub against the inside bottom surface of the nozzle. This will help remove any oxide buildup. Replace the nozzle, turn on the power and continue cutting. If the Parts-in-Place circuit (safety status indicator light) continues to trip after cleaning the consumables, replace them with a new set. Do not continue to cut with excessively worn consumables as this can cause damage to the torch head and will degrade cut quality.
2. To improve consumable life, here are some suggestions that may be useful:
 - a. Never drag the nozzle on the work surface if the output control knob is above the mid-range setting.
 - b. Make sure the air supply to the Pro-Cut is clean and free of oil. Use several extra in-line filters if necessary.
 - c. Use the lowest output setting possible to make a good quality cut at the desired cut speed.
 - d. Minimize dross buildup on the nozzle tip by starting the cut from the edge of the plate when possible.
 - e. Pierce cutting should be done only when necessary. If piercing, angle the torch about 30° from the plane perpendicular to the workpiece, transfer the arc, then bring the torch perpendicular to the work and begin parallel movement.
 - f. Reduce the number of pilot arc starts without transferring to the work.
 - g. Reduce the pilot arc time before transferring to the work.
 - h. Set air pressure to recommended setting. A higher or lower pressure will cause turbulence in the plasma arc, eroding the orifice of the nozzle tip.
 - i. Use only Lincoln consumable parts. These parts are patented. Using any other replacement consumables may cause damage to the torch or reduce cut quality.

PRO-CUT 55

LINCOLN
ELECTRIC

TABLE OF CONTENTS - ACCESSORIES -

Accessories.....	Section C
Options/Accessories.....	C-2

Return to Master TOC

Return to Master TOC

Return to Master TOC

Return to Master TOC

ACCESSORIES

GENERAL OPTIONS / ACCESSORIES

The following options/accessories are available for your Pro-Cut 55 from your local Lincoln Distributor.

K1600-1 Undercarriage - A valet style undercarriage with pull-out handle for machine only. Provides torch and work cable storage.

S22147-043 - Vortech™ nozzle with an .043" (1.2 mm) Orifice

S22147-068 - Vortech™ nozzle with an .068" (1.7 mm) Orifice

S22149 - Electrode - replacement electrodes for cutting.

S22150 - Shield Cup - This shields the torch tip and provides more visibility to the workpiece than the drag cup. The shield cup does not prevent the torch tip from touching the workpiece.

S22151 - Drag Cup - The drag cup protects the torch by preventing the torch from touching the workpiece.

K1571 Series - PCT 80 Torches come in 25' and 50' lengths in either hand held or mechanized versions.

ALWAYS USE GENUINE LINCOLN ELECTRIC ELECTRODES AND VORTECH™ NOZZLES

- Only Genuine Lincoln Electric consumables yield the best cutting performance for the Pro-Cut 55.
- The patent pending VORTECH™ nozzle provides an extra "kick" of swirl as the arc exits the nozzle, which improves cutting performance. No other nozzle has this capability or can match its performance.

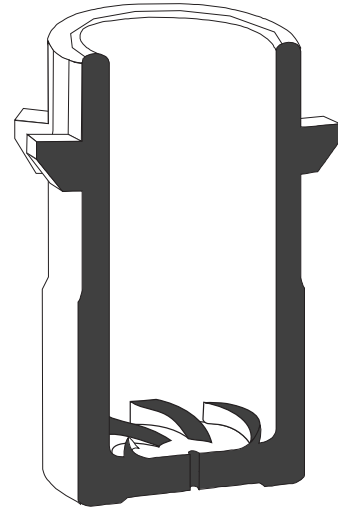

PRO-CUT 55



TABLE OF CONTENTS -MAINTENANCE-

MaintenanceSection D

- Safety Precautions.....D-2
- Input Filter Capacitor Discharge Procedure.....D-2
- Routine Maintenance.....D-3
- Periodic Maintenance.....D-3

Return to Master TOC

Return to Master TOC

Return to Master TOC

Return to Master TOC

MAINTENANCE

⚠ WARNING

ELECTRIC SHOCK can kill.



- Have an electrician install and service this equipment.
- Turn the input power off at the fuse box before working on equipment.
- Do not touch electrically hot parts.
- Prior to performing preventative maintenance, perform the following capacitor discharge procedure to avoid electric shock.

INPUT FILTER CAPACITOR DISCHARGE PROCEDURE

1. Turn off input power or disconnect input power lines.
2. Remove the 5/16 in. hex head screws from the side and top of the machine and remove wrap-around machine cover.
3. Be careful not to make contact with the capacitor terminals that are located on the top and bottom of the Power Board on the right side of the machine.

4. Obtain a high resistance and high wattage resistor (25-1000 ohms and 25 watts minimum). This resistor is not supplied with machine. NEVER USE A SHORTING STRAP FOR THIS PROCEDURE.
5. Locate the two capacitor terminals (large hex head cap screws) on the top and bottom of the Power Board shown in Figure D.1.
6. Use electrically insulated gloves and insulated pliers. Hold the body of the resistor and connect resistor leads across the two capacitor terminals. Hold the resistor in place for 10 seconds. DO NOT TOUCH CAPACITOR TERMINALS WITH YOUR BARE HANDS.
7. Repeat the discharge procedure for the other capacitor.
8. Check voltage across the terminals of all capacitors with a DC voltmeter. Polarity of capacitor terminals is marked on the Power Board above terminals. Voltage should be zero. If any voltage remains, repeat this capacitor discharge procedure.

FIGURE D.1 — LOCATION OF INPUT FILTER CAPACITOR TERMINALS

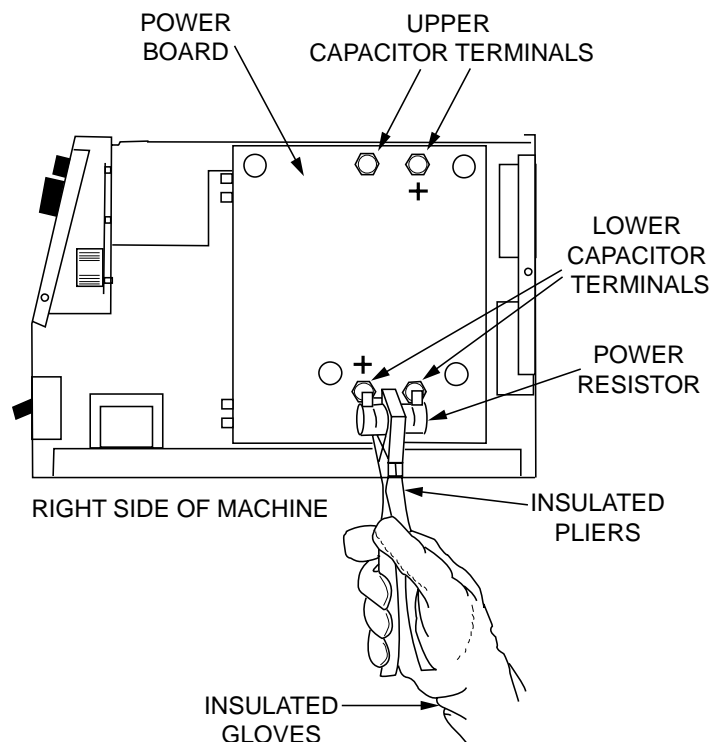

PRO-CUT 55

LINCOLN
ELECTRIC

ROUTINE MAINTENANCE

1. Keep the cutting or gouging area and the area around the machine clean and free of combustible materials. No debris should be allowed to collect which could obstruct air flow to the machine.
2. Every 6 months or so, the machine should be cleaned with a low pressure airstream. Keeping the machine clean will result in cooler operation and higher reliability. Be sure to clean these areas (Refer to **Figure D.2**):
 - Power, Output and Control printed circuit boards and heat sinks
 - Power Switch
 - Main Transformer
 - Input Rectifier
3. Examine the sheet metal case for dents or breakage. Repair the case as required. Keep the case in good condition to insure that high voltage parts are protected and correct spacings are maintained. All external sheet metal screws must be in place to insure case strength and electrical ground continuity.
4. Check the air regulator filter to be sure it does not become clogged. The air filter on the machine is self draining and will not have to be emptied.
5. Check the filter element every several months to see if it is clogged (weekly in very dirty environments). Replace if necessary by first removing the two screws that attach the filter cage to the back panel assembly, then slide the cage away from the back of the machine and remove. Next, twist the clear filter bowl until it comes off (be careful not to lose the o-ring seated at the top of the bowl threads). Unscrew the filter element and replace with new element. Assemble parts in reverse order as described above.
6. Inspect the cable periodically for any slits or puncture marks in the cable jacket. Replace if necessary. Check to make sure that nothing is crushing the cable and blocking the flow of air through the air tube inside. Also, check for kinks in the cable periodically and relieve any so as not to restrict the flow of air to the torch.

PERIODIC MAINTENANCE

WARNING

ELECTRIC SHOCK can kill.



- Turn off machine at the disconnect switch on the front of the machine before tightening, cleaning or replacing consumables.

Change consumables as required.

1. Thermal Protection

Two thermostats protect the machine from excessive operating temperatures. Excessive temperatures may be caused by a lack of cooling air or by operating the machine beyond the duty cycle and output rating. If excessive operating temperatures should occur, the yellow thermal LED will light and the thermostat will prevent output voltage or current.

Thermostats are self-resetting once the machine cools sufficiently. If the thermostat shutdown was caused by excessive output or duty cycle and the fan is operating normally, the Power Switch may be left on and the reset should occur within a 15 minute period. If the fan is not turning or the air intake louvers were obstructed, then the power must be switched off and the fan problem or air obstruction must be corrected.

2. Filter Capacitor Conditioning (Pro-Cut 55, 400-460 VAC only)

A protection circuit is included to monitor the voltage across filter capacitors C1 and C2. In the event that the capacitor voltage is too high, the protection circuit will prevent output. The protection circuit may prevent output providing all these circumstances are met:

- a. Machine is connected for 400-460 VAC input.
- b. Machine did not have power applied for many months.
- c. Machine will not produce output when power is first switched on.

If these circumstances apply, the proper action is to switch the machine on and let it idle for up to 30 minutes. This is required to condition the filter capacitors after an extended storage time. The protection circuit will automatically reset once the capacitor conditioning and resultant voltage levels are acceptable. It may be necessary to turn the power switch off and back on again after this period.

PRO-CUT 55



Maintenance

FIGURE D.2 – MAJOR COMPONENT LOCATIONS

- 1. Case Front
- 2. Case Back
- 3. Primary Power Board
- 4. Output Power Board Assembly
- 5. Control Board
- 6. Case Wraparound
- 7. Machine Base
- 8. Auxiliary Transformer
- 9. Main Transformer

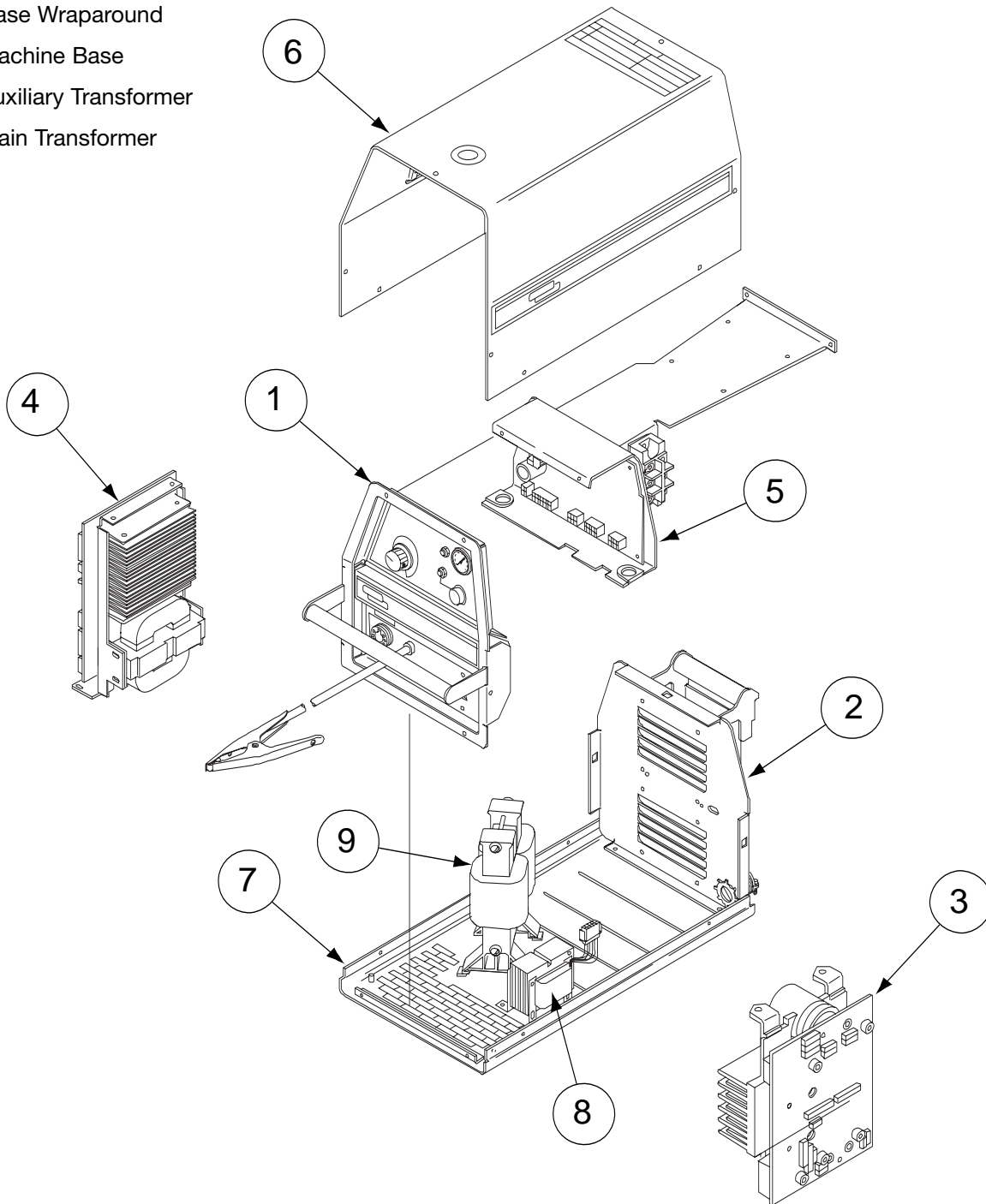

PRO-CUT 55



Return to Section TOC

Return to Section TOC

Return to Section TOC

Return to Section TOC

Return to Master TOC

Return to Master TOC

Return to Master TOC

Return to Master TOC

TABLE OF CONTENTS -THEORY OF OPERATION SECTION-

Theory of OperationSection E

- General DescriptionE-2
- Input Line Voltage, Contactor and Main Transformer.....E-2
- Precharge and ProtectionE-3
- Main TransformerE-4
- Output Board and TorchE-5
- Control and Display Boards.....E-6
- Protection CircuitsE-7
 - Overload Protection.....E-7
 - Thermal ProtectionE-7
- Insulated Gate Bipolar Transistor (IGBT) OperationE-8
- Pulse Width Modulation (PWM)E-9

FIGURE E.1 – PRO-CUT 55 BLOCK LOGIC DIAGRAM

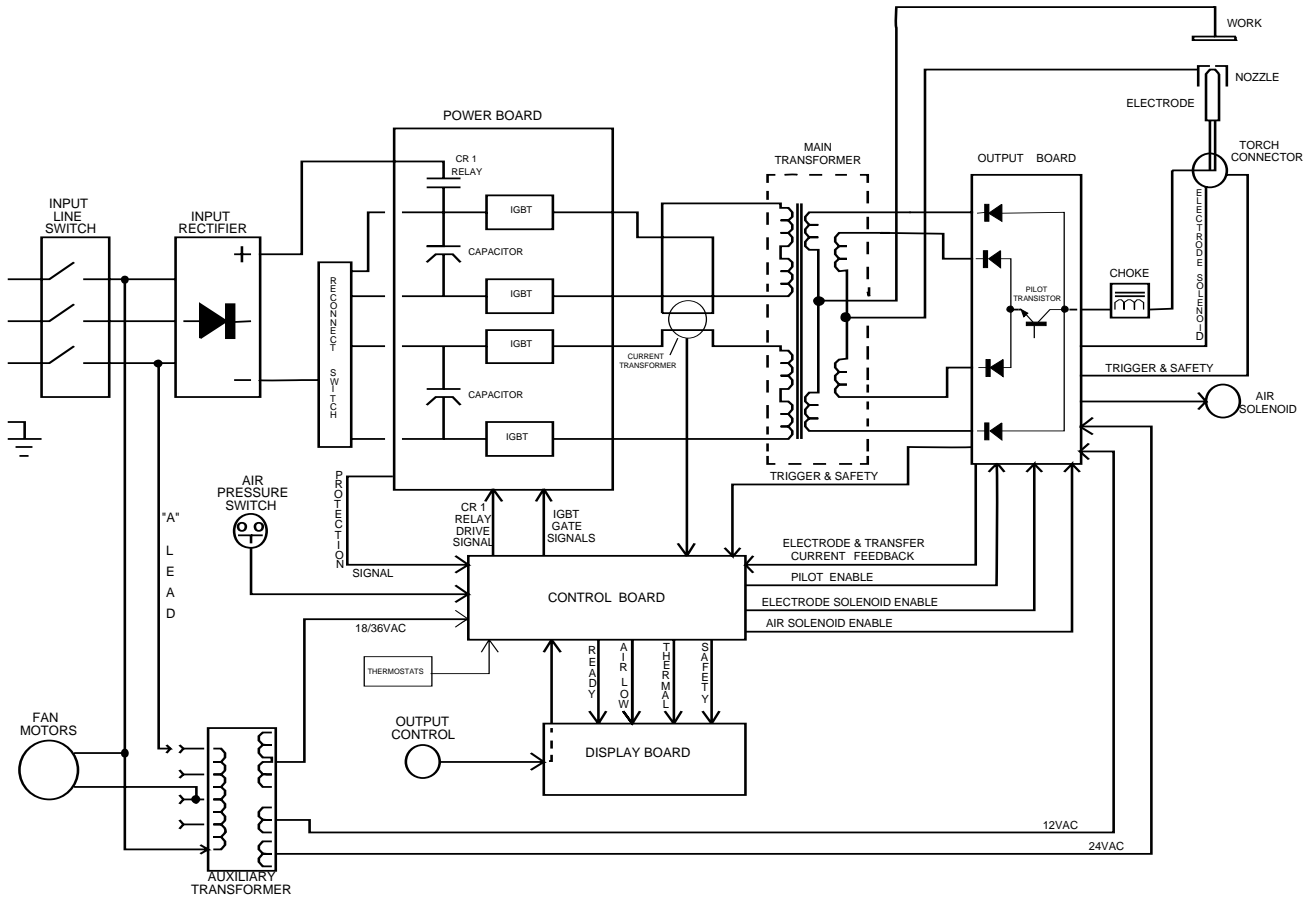

PRO-CUT 55



Return to Master TOC

Return to Master TOC

Return to Master TOC

Return to Master TOC

FIGURE E.2 – INPUT LINE VOLTAGE

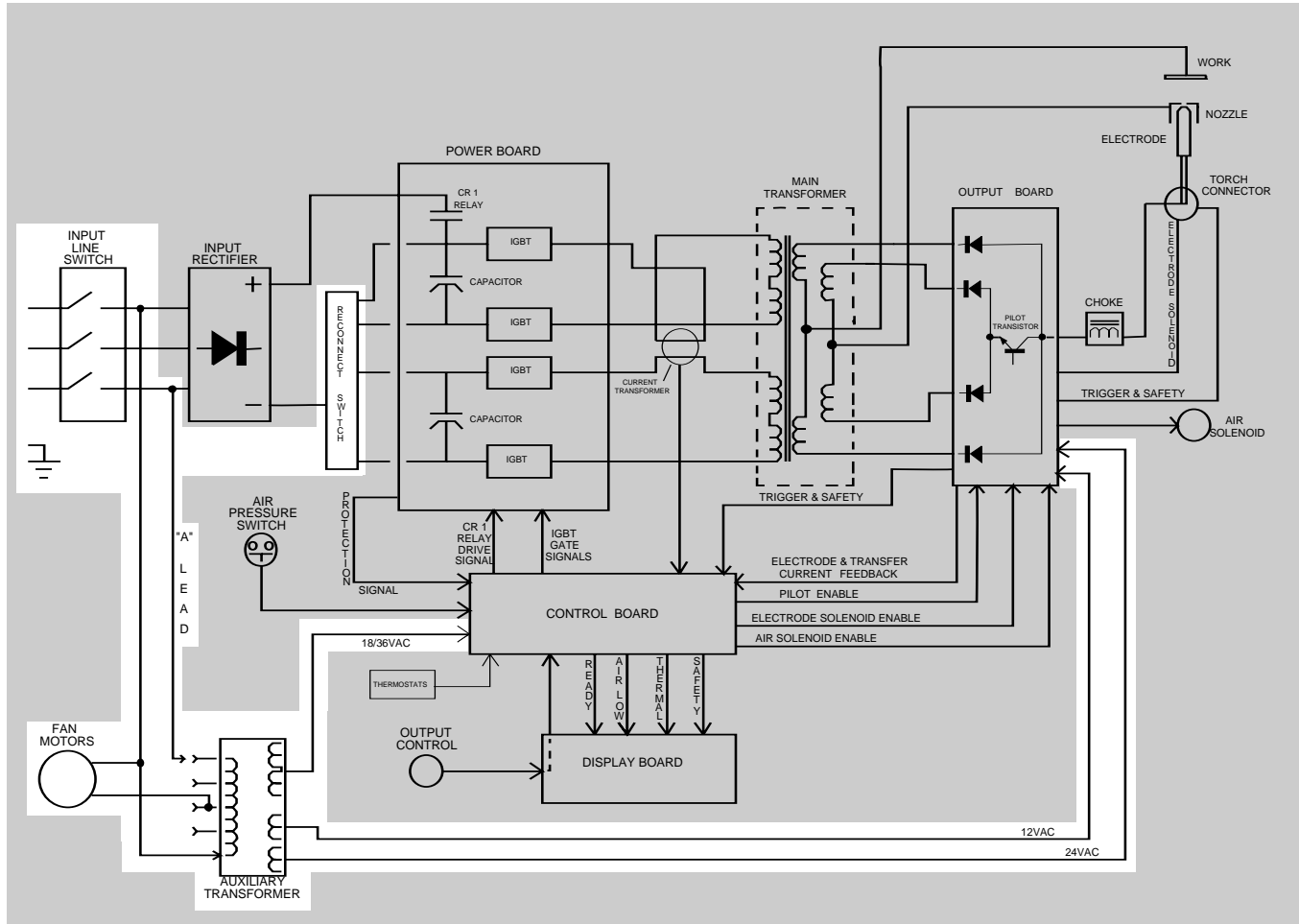

GENERAL DESCRIPTION

The Pro-Cut 55 is a constant current, continuous control plasma cutting power source. The inverter based power supply design is controlled by a microprocessor control board. The control system has a safety mechanism to insure that the nozzle and electrode are in place before cutting or gouging. The Pro-Cut 55 initiates the plasma arc with a simple, yet reliable, touch start mechanism. This system eliminates many of the problems associated with hi-frequency type start systems.

INPUT LINE VOLTAGE, CONTACTOR AND MAIN TRANSFORMER

The single-phase or three-phase input power of 200-230 or 400 to 460 volts AC is connected to the machine, via an input line cord, to a switch located on the front panel.

A reconnect panel and voltage range switch allow the user to configure the machine for either a low or high input voltage and also connect the auxiliary transformer for the appropriate input voltage.

The auxiliary transformer develops the appropriate AC voltages to operate the cooling fans, the control board and the plasma output board.

NOTE: Unshaded areas of Block Logic Diagram are the subject of discussion.

PRO-CUT 55

LINCOLN
ELECTRIC

Return to Section TOC
Return to Master TOC
Return to Section TOC
Return to Master TOC
Return to Section TOC
Return to Master TOC
Return to Section TOC
Return to Master TOC

FIGURE E.3 – PRECHARGE AND PROTECTION

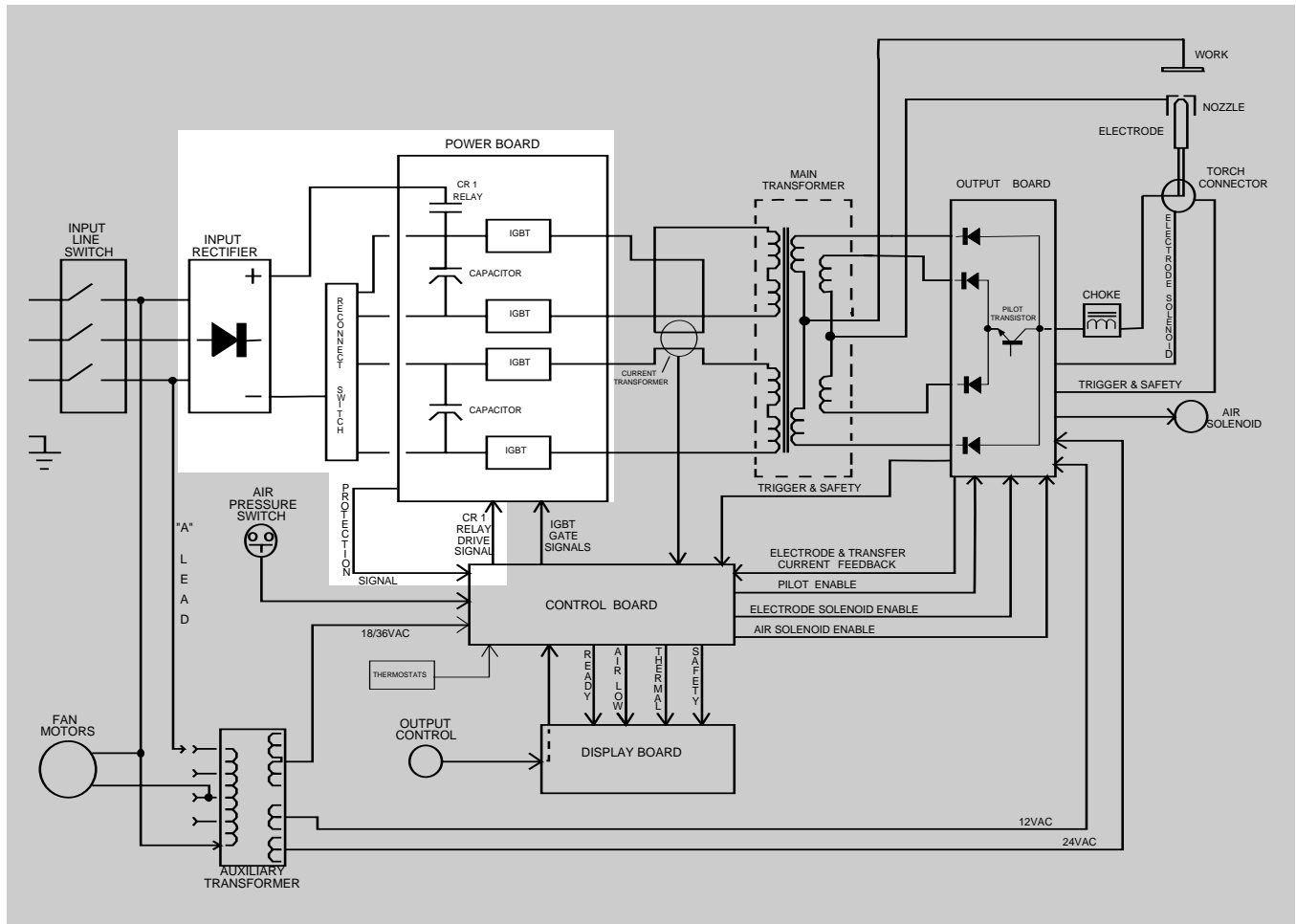

PRECHARGE AND PROTECTION

The input voltage is rectified by the input rectifier. The resultant DC voltage is applied, through the reconnect switch, to the power board. The power board contains precharging circuitry for the safe charging of the input filter capacitors. Once the capacitors are precharged and balanced the control board activates the CR1 input relay. This connects full input power to the filter capacitors. When the filter capacitors are fully charged they act as power supplies for the IGBT switching circuit. The Insulated Gate Bipolar Transistors supply the main transformer primary winding with DC current flow. See **IGBT Operation** discussion and diagrams in this section.

The power board also monitors the filter capacitors for voltage balance and under or overvoltage. If either should occur, the appropriate signal is sent to the control board to deactivate the CR1 input relay. The machine output will also be disabled.

NOTE: Unshaded areas of Block Logic Diagram are the subject of discussion.

PRO-CUT 55

LINCOLN
ELECTRIC

Return to Section TOC
Return to Master TOC
Return to Section TOC
Return to Master TOC
Return to Section TOC
Return to Master TOC
Return to Section TOC
Return to Master TOC

FIGURE E.4 – MAIN TRANSFORMER

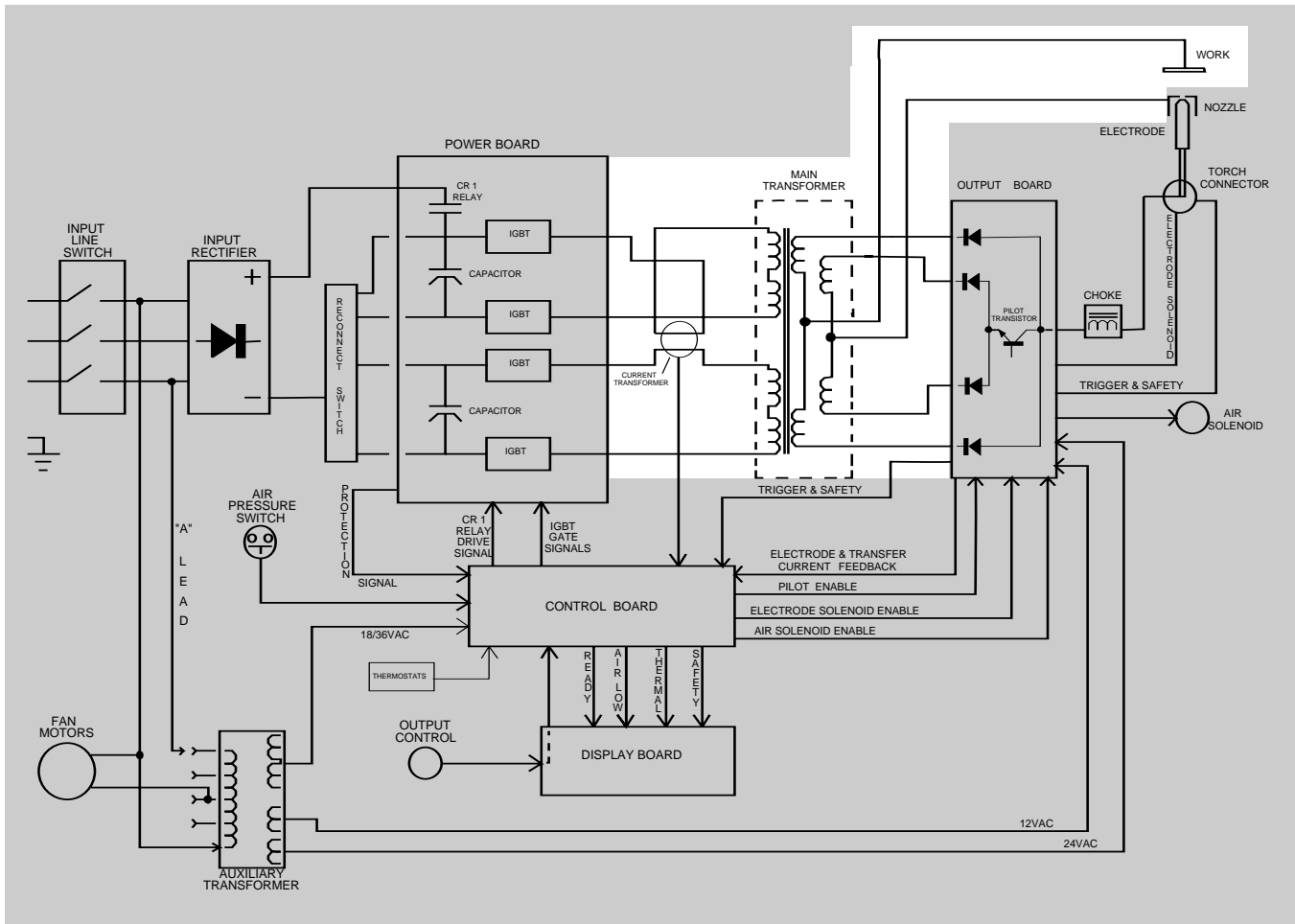

MAIN TRANSFORMER

Each IGBT pair acts as a switch assembly. Each assembly feeds a separate, oppositely wound primary winding of the main transformer. The reverse direction of current flow through the main transformer primaries and the offset timing of the IGBT pairs induce an AC square wave output signal at the secondary of the main transformer.

The DC current flow through each primary winding is redirected or "clamped" back to each respective filter capacitor when the IGBTs are turned off. This is needed due to the inductance of the transformer primary winding.

The primary currents also pass through the current transformer, which sends a signal to the control board. If the primary currents are not equal, the control board compensates by adjusting the IGBT gate signals.

The firing of both IGBT pairs occurs during halves of the 50 microsecond intervals, creating a constant 20KHZ output.

The secondary portion of the main transformer is made up of two separate windings. One secondary winding supplies the electrode-to-work voltage. This is the high current winding, which is capable of supplying maximum output current during the cutting process.

The other secondary winding supplies the electrode-to-nozzle voltage for the pilot arc current. The conductor in this winding is smaller since the pilot current is considerably less than the cutting current. While one winding is conducting the other winding is at a limited voltage and aids in the arc transfer to and from the workpiece.

THEORY OF OPERATION

FIGURE E.5 – PLASMA OUTPUT BOARD AND TORCH

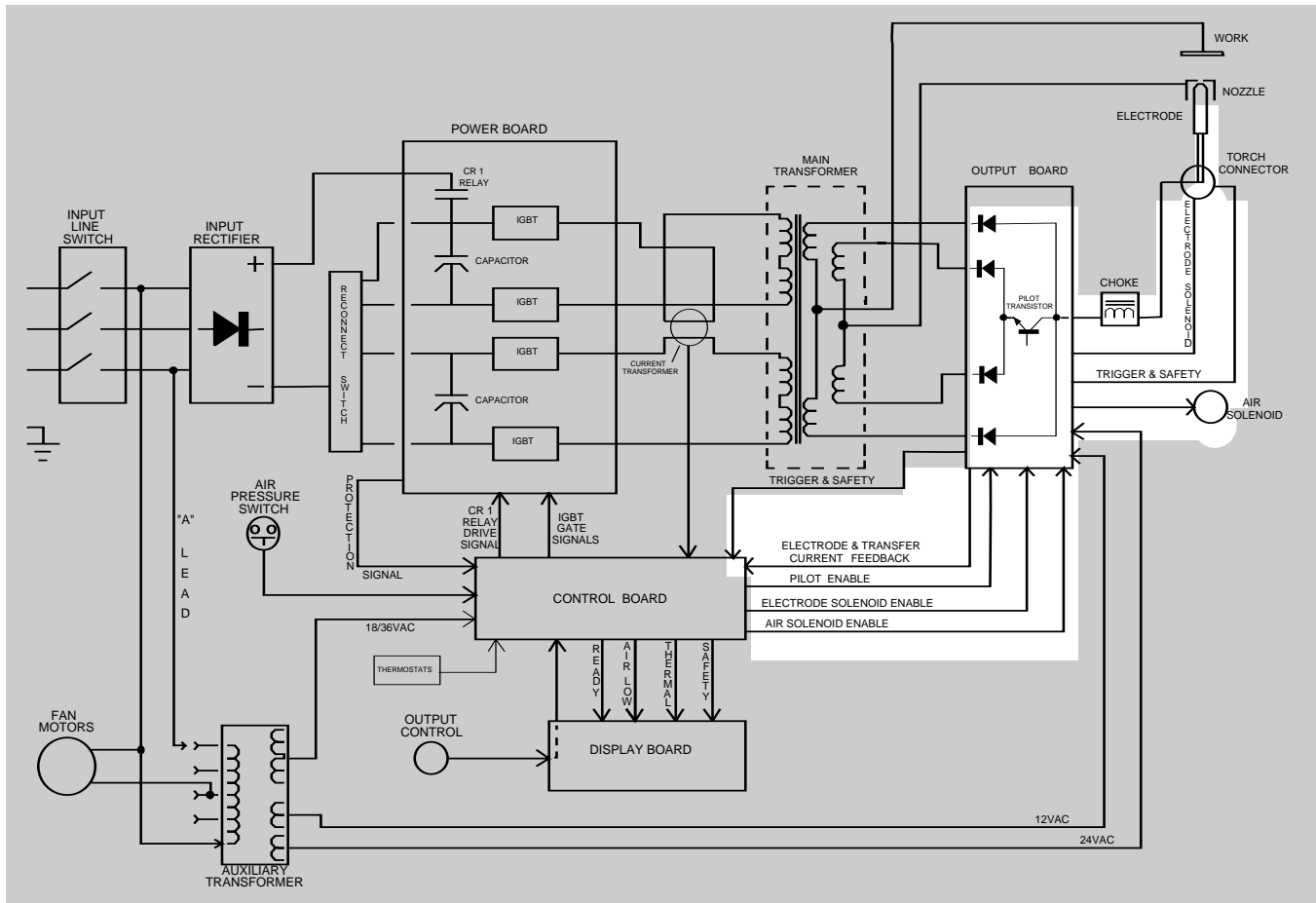

OUTPUT BOARD AND TORCH

The output board contains an Insulated Gate Bipolar Transistor (IGBT) which, upon receiving a pilot signal from the control board, either enables or disables the current in the pilot winding. The cutting and pilot rectifier diodes are also incorporated in the output board. There are two diodes for each of the secondary windings.

There are two P.C. board mounted current sensors. One sensor regulates pilot and cutting current. The other sensor indicates to the control board when and how much current transfers to the workpiece.

The output board also includes the trigger circuitry, the gas solenoid driver, the electrode solenoid driver and the torch parts-in-place circuitry.

The output choke, which is in series with both the pilot circuit and the cutting circuit, provides current filtering to enhance arc stability.

The PCT 80 torch uses a patented touch start mechanism that provides superior starting performance over other touch start systems. The torch head consists of 3 major parts: torch body, insulator and piston. The insulator provides an electrical barrier between the piston and torch body. The piston provides a path for electrical current to the nozzle. The piston also drives the electrode to the nozzle for arc initiation. The torch body contains the main torch components: the trigger, pilot arc, cutting arc, and air flow systems are included.

A copper nozzle with a patented internal swirl is used to focus the arc. A small, precise hole in the end of the nozzle constricts the arc and increases the current density. As the air enters the torch head, it is directed between the electrode and nozzle for maximum electrode cooling. A portion of the cooling air exits the chamber through vents in the side of the nozzle. A swirl texture located inside the bottom of the nozzle increases the plenum air swirl strength, and improves arc start reliability and parts-in-place verification.

Plasma arc initiation occurs as follows: First, in the idle state, a spring inside the torch head pushes the piston and electrode forward to make continuity with the nozzle. When the trigger is pulled, air flow begins and creates enough back force on the electrode to overcome the force of the spring. However, the solenoid valve allows enough forward force on the piston to maintain continuity between the consumables. After this continuity has been verified by the Pro-Cut's parts-in-place circuit, output current is established and regulated. Once the current stabilizes, the solenoid valve turns off, removing the forward force on the piston. The back pressure drives the piston and electrode away from the nozzle, creating the plasma arc. The air stream forces the arc out the orifice of the nozzle. This appears as a pilot arc, which can then be transferred for cutting.

PRO-CUT 55

LINCOLN
ELECTRIC

Return to Section TOC
Return to Master TOC

Return to Section TOC
Return to Master TOC

Return to Section TOC
Return to Master TOC

Return to Section TOC
Return to Master TOC

THEORY OF OPERATION

FIGURE E.6 – CONTROL AND DISPLAY BOARDS

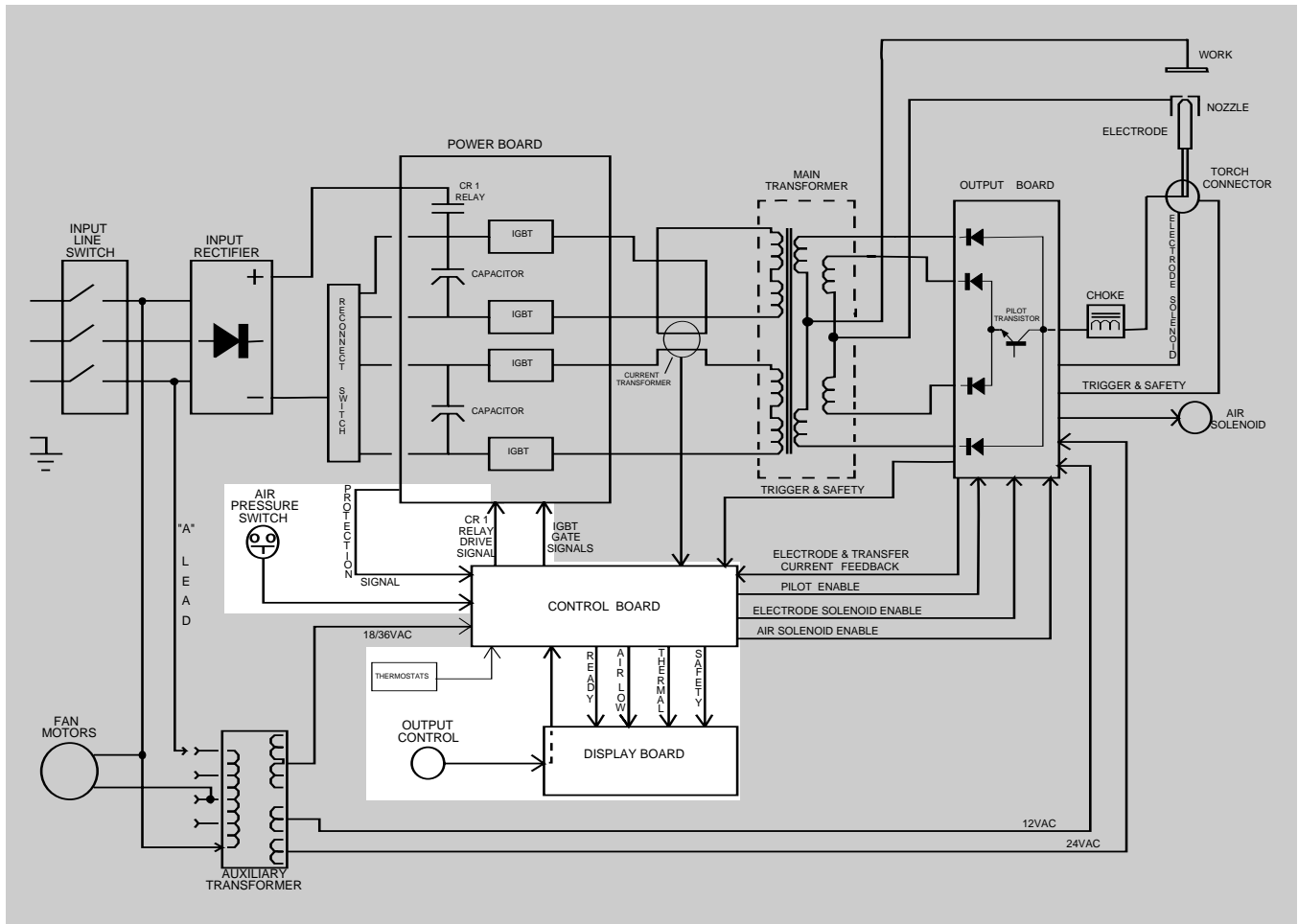

CONTROL AND DISPLAY BOARDS

The control board receives status and analog feedback signals from the output board, display board, power board and various sensors. The processor interprets these signals, makes decisions and changes machine mode and output to satisfy the requirements as defined by the internal software. The control board

regulates the output of the machine by controlling the IGBT switching times through pulse width modulation circuitry. See **Pulse Width Modulation** in this section.

The display board receives commands from the control board and, via indicator lights, communicates Pro-Cut 55 status and operating conditions to the user.

PRO-CUT 55

LINCOLN
ELECTRIC

THEORY OF OPERATION

PROTECTION CIRCUITS

Protection circuits are designed into the Pro-Cut 55 machine to sense trouble and shut down the machine before the trouble damages internal machine components. Both overload and thermal protection circuits are included.

OVERLOAD PROTECTION

The Pro-Cut 55 is electrically protected from producing higher than normal output currents. If the output current exceeds 50-60 amps, an electronic protection circuit limits the current to within the capabilities of the machine.

Another protection circuit monitors the voltage across the input filter capacitors. If the filter capacitor voltage is too high, too low or not balanced the protection circuit may prevent machine output.

THERMAL PROTECTION

Two thermostats protect the machine from excessive operating temperatures. One thermostat is located on the output choke and the other on the power board IGBT heat sink. Excessive temperatures may be caused by a lack of cooling air or by operating the machine beyond the duty cycle and output rating. If excessive operating temperatures should occur, the thermal status indicator will light and the thermostat will prevent output voltage or current.

Thermostats are self-resetting once the machine cools sufficiently. If the thermostat shutdown was caused by excessive output or duty cycle and the fans are operating normally, the power switch may be left on and the reset should occur within a 15 minute period. If the fan or fans are not turning or the air intake louvers are obstructed, the input power must be removed and the fan problem or air obstruction must be corrected.

PRO-CUT 55



INSULATED GATE BIPOLAR TRANSISTOR (IGBT) OPERATION

An IGBT is a type of transistor. IGBTs are semiconductors well suited for high frequency switching and high current applications.

Drawing A shows an IGBT in a passive mode. There is no gate signal, zero volts relative to the source, and therefore, no current flow. The drain terminal of the IGBT may be connected to a voltage supply; but since there is no conduction the circuit will not supply current to components connected to the source. The circuit is turned off like a light switch in the OFF position.

Drawing B shows the IGBT in an active mode. When the gate signal, a positive DC voltage relative to the source, is applied to the gate terminal of the IGBT, it is capable of conducting current. A voltage supply connected to the drain terminal will allow the IGBT to conduct and supply current to circuit components coupled to the source. Current will flow through the conducting IGBT to downstream components as long as the positive gate signal is present. This is similar to turning ON a light switch.

FIGURE E.7 – IGBT OPERATION

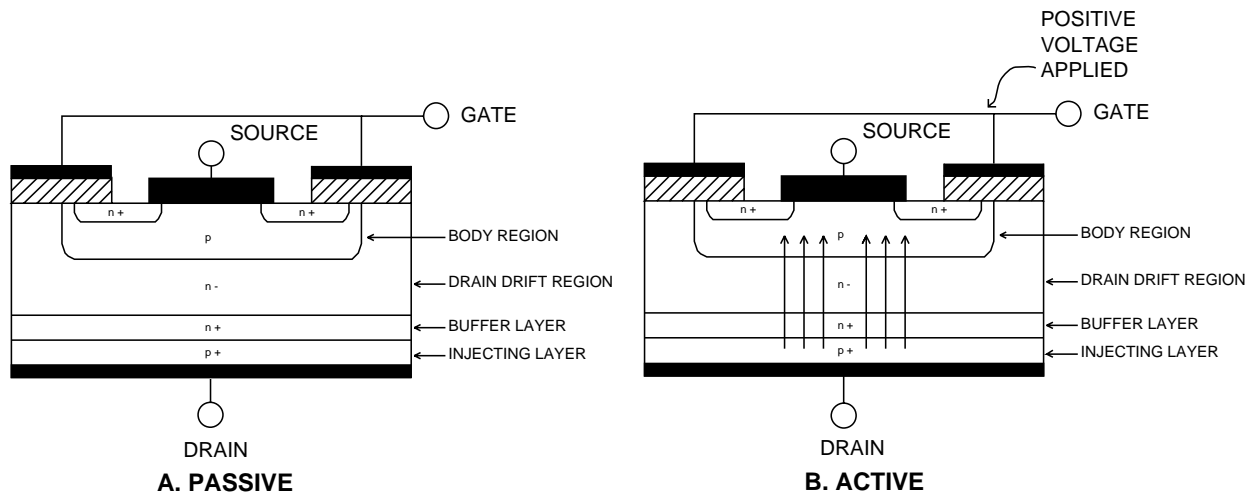

Return to Section TOC
 Return to Master TOC
 Return to Section TOC
 Return to Master TOC
 Return to Section TOC
 Return to Master TOC
 Return to Section TOC
 Return to Master TOC

THEORY OF OPERATION

PULSE WIDTH MODULATION

The term PULSE WIDTH MODULATION describes how much time is devoted to conduction in the positive and negative portions of the cycle. Changing the pulse width is known as MODULATION. Pulse Width Modulation (PWM) is the varying of the pulse width over the allowed range of a cycle to affect the output of the machine.

MINIMUM OUTPUT

By controlling the duration of the gate signal, the IGBT is turned on and off for different durations during a cycle. The top drawing below shows the minimum output signal possible over a 50-microsecond time period.

The positive portion of the signal represents one IGBT group¹ conducting for 1 microsecond. The negative portion is the other IGBT group¹. The dwell time (off time) is 48 microseconds (both IGBT groups off). Since only 2 microseconds of the 50-microsecond time period is devoted to conducting, the output power is minimized.

MAXIMUM OUTPUT

By holding the gate signals on for 22 microseconds each and allowing only 3 microseconds of dwell time (off time) during the 50-microsecond cycle, the output is maximized. The darkened area under the top curve can be compared to the area under the bottom curve. The more dark area under the curve, the more power is present.

¹ An IGBT group consists of two IGBT modules feeding one transformer primary winding.

FIGURE E.8 – TYPICAL IGBT OUTPUTS

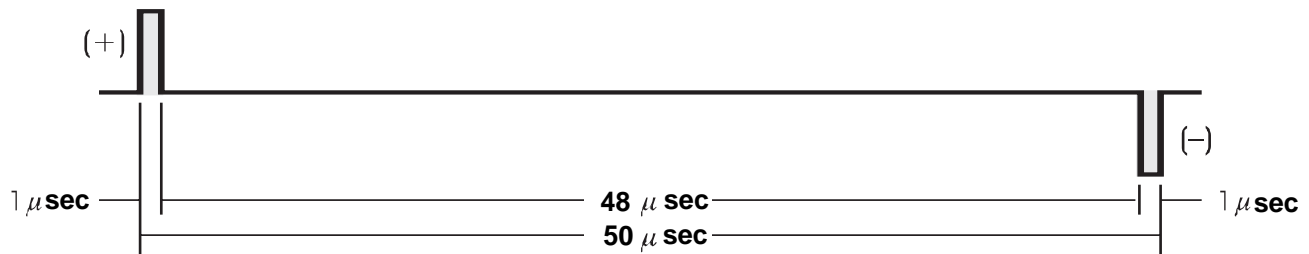

MINIMUM OUTPUT

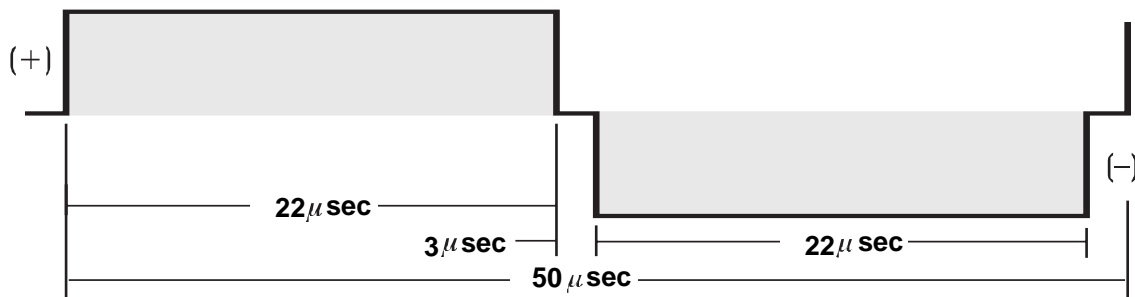

MAXIMUM OUTPUT

Return to Section TOC
Return to Master TOC

Return to Section TOC
Return to Master TOC

Return to Section TOC
Return to Master TOC

Return to Section TOC
Return to Master TOC

PRO-CUT 55



TABLE OF CONTENTS

TROUBLESHOOTING & REPAIR SECTION

Troubleshooting & Repair Section	Section F
How to Use Troubleshooting Guide	F-2
PC Board Troubleshooting Procedures and Replacement	F-3
Troubleshooting Guide.....	F-4
Test Procedures	
Troubleshooting Flow Chart	F-10
Input Filter Capacitor Discharge Procedure.....	F-12
Input Rectifier Test	F-14
Primary Power Board Resistance Test and Capacitor Voltage Test	F-18
Output Power Board Resistance Test.....	F-24
Torch Continuity and Solenoid Test	F-28
Air/Gas Solenoid Test.....	F-32
T2 Auxiliary Transformer Test	F-34
Trigger Circuit Test	F-38
Low Voltage Circuit Test.....	F-44
Replacement Procedures	
Control Board Removal and Replacement	F-50
Display Board Removal and Replacement	F-54
Output Power Board Removal and Replacement.....	F-58
Primary Power Board and Filter Capacitor Removal and Replacement	F-62
Input Rectifier Bridge Removal and Replacement.....	F-66
Retest after Repair	F-69

TROUBLESHOOTING & REPAIR

HOW TO USE TROUBLESHOOTING GUIDE

⚠ WARNING

Service and repair should be performed by only Lincoln Electric Factory Trained Personnel. Unauthorized repairs performed on this equipment may result in danger to the technician and machine operator and will invalidate your factory warranty. For your safety and to avoid Electrical Shock, please observe all safety notes and precautions detailed throughout this manual.

This Troubleshooting Guide is provided to help you locate and repair possible machine malfunctions. Simply follow the three-step procedure listed below.

Step 1. LOCATE PROBLEM (SYMPTOM). Look under the column labeled “PROBLEM (SYMPTOMS)”. This column describes possible symptoms that the machine may exhibit. Find the listing that best describes the symptom that the machine is exhibiting. Symptoms are grouped into four main categories: Output Problems, Function Problems, Cutting Problems and LED Function Problems.

Step 2. PERFORM EXTERNAL TESTS. The second column, labeled “POSSIBLE AREAS OF MISADJUSTMENT(S)”, lists the obvious external possibilities that may contribute to the machine symptom. Perform these tests/checks in the order listed. In general, these tests can be conducted without removing the case wrap-around cover.

Step 3. PERFORM COMPONENT TESTS. The last column, labeled “Recommended Course of Action” lists the most likely components that may have failed in your machine. It also specifies the appropriate test procedure to verify that the subject component is either good or bad. If there are a number of possible components, check the components in the order listed to eliminate one possibility at a time until you locate the cause of your problem.

All of the referenced test procedures referred to in the Troubleshooting Guide are described in detail at the end of this chapter. Refer to the Troubleshooting and Repair Table of Contents to locate each specific Test Procedure. All of the referred to test points, components, terminal strips, etc., can be found on the referenced electrical wiring diagrams and schematics. Refer to the Electrical Diagrams Section Table of Contents to locate the appropriate diagram.

⚠ CAUTION

If for any reason you do not understand the test procedures or are unable to perform the test/repairs safely, contact the Lincoln Electric Service Department for electrical troubleshooting assistance before you proceed. Call 1-888-935-3877.

PRO-CUT 55



TROUBLESHOOTING & REPAIR

PC BOARD TROUBLESHOOTING PROCEDURES

⚠ WARNING



ELECTRIC SHOCK can kill.

- Have an electrician install and service this equipment. Turn the input power OFF at the fuse box before working on equipment. Do not touch electrically hot parts.

⚠ CAUTION

Sometimes machine failures appear to be due to PC board failures. These problems can sometimes be traced to poor electrical connections. To avoid problems when troubleshooting and replacing PC boards, please use the following procedure:

1. Determine to the best of your technical ability that the PC board is the most likely component causing the failure symptom.
2. Check for loose connections at the PC board to assure that the PC board is properly connected.
3. If the problem persists, replace the suspect PC board using standard practices to avoid static electrical damage and electrical shock. Read the warning inside the static resistant bag and perform the following procedures:

PC board can be damaged by static electricity.



ATTENTION
Static-Sensitive
Devices
Handle only at
Static-Safe
Workstations

- Remove your body's static charge before opening the static-shielding bag. Wear an anti-static wrist strap. For safety, use a 1 Meg ohm resistive cord connected to a grounded part of the equipment frame.

- If you don't have a wrist strap, touch an un-painted, grounded, part of the equipment frame. Keep touching the frame to prevent static build-up. Be sure not to touch any electrically live parts at the same time.

- Tools which come in contact with the PC board must be either conductive, anti-static or static-dissipative.

- Remove the PC board from the static-shielding bag and place it directly into the equipment. Don't set the PC board on or near paper, plastic or cloth which could have a static charge. If the PC board can't be installed immediately, put it back in the static-shielding bag.

- If the PC board uses protective shorting jumpers, don't remove them until installation is complete.

- If you return a PC board to The Lincoln Electric Company for credit, it must be in the static-shielding bag. This will prevent further damage and allow proper failure analysis.

4. Test the machine to determine if the failure symptom has been corrected by the replacement PC board.

NOTE: It is desirable to have a spare (known good) PC board available for PC board troubleshooting.

NOTE: Allow the machine to heat up so that all electrical components can reach their operating temperature.

5. Remove the replacement PC board and substitute it with the original PC board to recreate the original problem.

a. If the original problem does not reappear by substituting the original board, then the PC board was not the problem. Continue to look for bad connections in the control wiring harness, junction blocks, and terminal strips.

b. If the original problem is recreated by the substitution of the original board, then the PC board was the problem. Reinstall the replacement PC board and test the machine.

6. Always indicate that this procedure was followed when warranty reports are to be submitted.

NOTE: Following this procedure and writing on the warranty report, "INSTALLED AND SWITCHED PC BOARDS TO VERIFY PROBLEM," will help avoid denial of legitimate PC board warranty claims.

TROUBLESHOOTING & REPAIR

TROUBLESHOOTING GUIDE

Observe Safety Guidelines detailed in the beginning of this manual.

PROBLEMS (SYMPTOMS)	POSSIBLE AREAS OF MISADJUSTMENT(S)	RECOMMENDED COURSE OF ACTION
OUTPUT PROBLEMS		
Major physical or electrical damage is evident when the sheet metal cover(s) are removed.	1. Contact your local authorized Lincoln Electric Field Service Facility for technical assistance.	1. Contact the Lincoln Electric Service Department, 216-383-2531 or 1-888-935-3877.
Machine is dead – no output – no fan – no status indicator lights.	<ol style="list-style-type: none"> 1. Make sure that the input power switch is in the “ON” position. 2. Check the input voltage at the machine. Input voltage must match the rating plate and the reconnect panel. 3. Check for blown or missing fuses in the input lines and the 0.6 amp slow blow reconnect fuse. 	<ol style="list-style-type: none"> 1. Check the input power switch (S1) for proper operation. See the Wiring Diagram. 2. Check the leads associated with the power switch (S1) and the auxiliary transformer (T2) for loose or faulty connections. See the Wiring Diagram. 3. Perform the Auxiliary Transformer Test.
Machine is dead - not output - no status indicator lights - fans run.	1. Check the input voltage at the machine. Input voltage must match the rating plate and the reconnect panel.	<ol style="list-style-type: none"> 1. Perform the Auxiliary Transformer Test. 2. Perform the Low Voltage Circuit Test. 3. Perform the Input Rectifier Test. 4. The control board may be faulty. Replace. 5. The display board may be faulty. Replace.
All status indicators remain immediately after power up.	1. The microprocessor has experienced a memory fault. Contact your Local Lincoln Authorized Field Service Facility.	1. The control board may be faulty. Replace.

⚠ CAUTION

If for any reason you do not understand the test procedures or are unable to perform the test/repairs safely, contact the Lincoln Electric Service Department for electrical troubleshooting assistance before you proceed. Call 1-888-935-3877.

Return to Section TOC
Return to Section TOC
Return to Section TOC
Return to Section TOC
Return to Section TOC
Return to Section TOC

Return to Master TOC

Return to Master TOC

Return to Master TOC

Return to Master TOC

TROUBLESHOOTING & REPAIR

TROUBLESHOOTING GUIDE

Observe Safety Guidelines detailed in the beginning of this manual.

PROBLEMS (SYMPTOMS)	POSSIBLE AREAS OF MISADJUSTMENT(S)	RECOMMENDED COURSE OF ACTION
FUNCTION PROBLEMS		
<p>All the status lights begin to blink within 5 seconds of power up.</p>	<ol style="list-style-type: none"> 1. Make sure the Pro-Cut 55 is reconnected correctly for the input voltage being applied. Be sure to remove input power and wait at least one minute before changing the position of the input voltage range switch. 2. If the machine is connected for high input voltage, the input capacitors may need conditioning. See Maintenance Section. 	<ol style="list-style-type: none"> 1. Perform the Primary Power Board Resistance Test and Capacitor Voltage Test. 2. Perform the Input Rectifier Test. 3. The control board may be faulty. Replace. 4. The primary power board may be faulty. Replace.
<p>The machine powers up properly, but there is no response when the gun trigger is pulled. Only the power LED is lit.</p>	<ol style="list-style-type: none"> 1. Make sure the torch is connected properly to the Pro-Cut 55 machine. 2. Make sure the air supply is connected and operating properly. 3. Make sure the torch head consumable parts are in place and in good condition. Replace if necessary. 	<ol style="list-style-type: none"> 1. Perform the Auxiliary Transformer Test. 2. Perform the Trigger Circuit Test. 3. Perform the Gas Solenoid Test. 4. Perform the Torch Continuity and Solenoid Test. 5. The control board may be faulty. Replace. 6. The output power board may be faulty. Perform the Output Board Resistance Test.
<p>When the torch trigger is pulled, air begins to flow; but no pilot arc is established.</p>	<ol style="list-style-type: none"> 1. Make sure the torch consumables are in place and in good condition. Replace if necessary. 2. Make sure the air pressure is set at 70 psi (448 kPa.) and the flow rate is at 6 CFM. 3. Make sure there are no kinks or restrictions for air flow in the torch cable. 	<ol style="list-style-type: none"> 1. Perform the Torch Continuity and Solenoid Test. 2. Perform the Low Voltage Circuit Test. 3. The output board may be faulty. Perform the Output Board Resistance Test. 4. The control board may be faulty. Replace.

⚠ CAUTION

If for any reason you do not understand the test procedures or are unable to perform the test/repairs safely, contact the Lincoln Electric Service Department for electrical troubleshooting assistance before you proceed. Call 1-888-935-3877.

TROUBLESHOOTING & REPAIR

TROUBLESHOOTING GUIDE

Observe Safety Guidelines detailed in the beginning of this manual.

PROBLEMS (SYMPTOMS)	POSSIBLE AREAS OF MISADJUSTMENT(S)	RECOMMENDED COURSE OF ACTION
FUNCTION PROBLEMS		
<p>The air begins to flow when the torch trigger is pulled. There is a very brief pilot arc. (Normal is 3 seconds.) The sequence is repeated with subsequent trigger pulls.</p>	<ol style="list-style-type: none"> 1. Make sure the air pressure is set at 70 psi (448 kPa.) and the flow rate is at 6 CFM. 2. Make sure the torch consumables are in place and in good condition. 3. Make sure the air flow is not restricted. 4. Make sure the air hose and screen are not clogged. 	<ol style="list-style-type: none"> 1. Perform the Torch Continuity and Solenoid Test. 2. The output board may be faulty. Replace. 3. The control board may be faulty. Replace.
<p>The cutting arc starts but sputters badly.</p>	<ol style="list-style-type: none"> 1. Make sure the operating procedure is correct for the process. See the Operation section of this manual. 2. Make sure the work clamp is connected tightly to the workpiece. 3. Make sure the torch consumables are in place and in good condition. 4. Make sure the air supply is not contaminated with oil or excessive water. 5. Make sure the air pressure is set at 70 psi (448 kPa.) and the flow rate is at 6 CFM. 6. Make sure the air hose and screen are not clogged. 	<ol style="list-style-type: none"> 1. Perform the Torch Continuity and Solenoid Test. 2. The output board may be faulty. Replace. 3. The control board may be faulty. Replace.
<p>Nuisance safety trips</p>	<ol style="list-style-type: none"> 1. See Safety Status Indicator in the operation section. 2. Make sure the correct nozzles are being used for the material thickness. See Operation Section. 3. Make sure the output control is set correctly for the process. 	<ol style="list-style-type: none"> 1. The torch may be faulty. Check or replace. 2. The control board may be faulty. See Torch Continuity and Solenoid Test.

⚠ CAUTION

If for any reason you do not understand the test procedures or are unable to perform the test/repairs safely, contact the Lincoln Electric Service Department for electrical troubleshooting assistance before you proceed. Call 1-888-935-3877.

PRO-CUT 55



Return to Section TOC

Return to Section TOC

Return to Section TOC

Return to Section TOC

Return to Master TOC

Return to Master TOC

Return to Master TOC

Return to Master TOC

TROUBLESHOOTING & REPAIR

TROUBLESHOOTING GUIDE

Observe Safety Guidelines detailed in the beginning of this manual.

PROBLEMS (SYMPTOMS)	POSSIBLE AREAS OF MISADJUSTMENT(S)	RECOMMENDED COURSE OF ACTION
CUTTING PROBLEMS		
<p>The pilot arc is normal, but the arc will not transfer to the workpiece.</p>	<ol style="list-style-type: none"> 1. Make sure the operating procedure is correct for the process. See the Operation section of this manual. 2. Make sure the work clamp is connected tightly to the workpiece. 3. The workpiece must be electrically conductive material. 	<ol style="list-style-type: none"> 1. Check the lead connections X2, X4 and B21 at the output board. 2. Check the output control potentiometer (R1). Normal resistance is 10 ohms. Also check the associated leads for loose or faulty connections to the display board. See the Wiring Diagram. 3. Check leads #216, #218 and #219 between the display board and the control board. Check for loose or faulty connections. See the Wiring Diagram. 4. The control board may be faulty. Replace. 5. The output board may be faulty. Perform the Output Board Resistance Test. 6. The display board may be faulty. Replace.

⚠ CAUTION

If for any reason you do not understand the test procedures or are unable to perform the test/repairs safely, contact the Lincoln Electric Service Department for electrical troubleshooting assistance before you proceed. Call 1-888-935-3877.

PRO-CUT 55



Return to Section TOC

Return to Section TOC

Return to Section TOC

Return to Section TOC

Return to Master TOC

Return to Master TOC

Return to Master TOC

Return to Master TOC

TROUBLESHOOTING & REPAIR

TROUBLESHOOTING GUIDE

Observe Safety Guidelines detailed in the beginning of this manual.

PROBLEMS (SYMPTOMS)	POSSIBLE AREAS OF MISADJUSTMENT(S)	RECOMMENDED COURSE OF ACTION
LED FUNCTION PROBLEMS		
The Air Low LED is lit.	<ol style="list-style-type: none"> 1. Make sure there is at least 70 psi (448 kPa) of air pressure connected to the gas connection at the back of the Pro-Cut 55. 2. Press the purge button and set the regulator to 70 psi (448 kPa). Do not reset the air pressure while the air is off (not flowing). 	<ol style="list-style-type: none"> 1. The pressure switch (S5) or associated leads may be faulty. See the Wiring Diagram. 2. The control board may be faulty. Replace.
The Safety LED is flashing.	<ol style="list-style-type: none"> 1. Make sure there is a Lincoln PCT 80 torch connected properly to the Pro-Cut 55. 2. Make sure the torch consumables are in place and in good condition. 	<ol style="list-style-type: none"> 1. Perform the Torch Continuity and Solenoid Test. 2. Check leads "N", "E", #364, and #369 between the torch receptacle and the output board. See the Wiring Diagram. 3. The output board may be faulty. Replace.
The Safety LED is lit and ready.	<ol style="list-style-type: none"> 1. Press the reset button. If the torch and consumables are properly installed, the Safety LED should turn off. 	<ol style="list-style-type: none"> 1. The reset button or associated wiring may be faulty. See the Wiring Diagram. 2. Perform the Torch Continuity and Solenoid Test. 3. The control board may be faulty. Replace. 4. If the machine operates normally with the Safety LED on, the display board may be faulty. Replace.

⚠ CAUTION

If for any reason you do not understand the test procedures or are unable to perform the test/repairs safely, contact the Lincoln Electric Service Department for electrical troubleshooting assistance before you proceed. Call 1-888-935-3877.

PRO-CUT 55



Return to Section TOC
Return to Master TOC

TROUBLESHOOTING & REPAIR

TROUBLESHOOTING GUIDE

Observe Safety Guidelines detailed in the beginning of this manual.

PROBLEMS (SYMPTOMS)	POSSIBLE AREAS OF MISADJUSTMENT(S)	RECOMMENDED COURSE OF ACTION
LED FUNCTION PROBLEMS		
<p>The Thermal LED is lit.</p>	<ol style="list-style-type: none"> 1. One of the machine's thermostats has tripped. Do not turn the Pro-Cut 55 off. Allow the machine to cool. The thermostat(s) will reset themselves. <p>Either the duty cycle has been exceeded, the fans are not functioning or the louvers are blocked.</p>	<ol style="list-style-type: none"> 1. The thermostat may be faulty. Replace. 2. The control board may be faulty. Replace. 3. If the machine operates normally with the Thermal LED lit, the display board may be faulty. Replace.

⚠ CAUTION

If for any reason you do not understand the test procedures or are unable to perform the test/repairs safely, contact the Lincoln Electric Service Department for electrical troubleshooting assistance before you proceed. Call 1-888-935-3877.

Return to Section TOC

Return to Master TOC

Return to Section TOC

Return to Master TOC

Return to Section TOC

Return to Master TOC

Return to Section TOC

Return to Master TOC

Return to Section TOC | Return to Section TOC | Return to Section TOC | Return to Master TOC | Return to Master TOC | Return to Master TOC

PRO-CUT TROUBLESHOOTING FLOWCHART

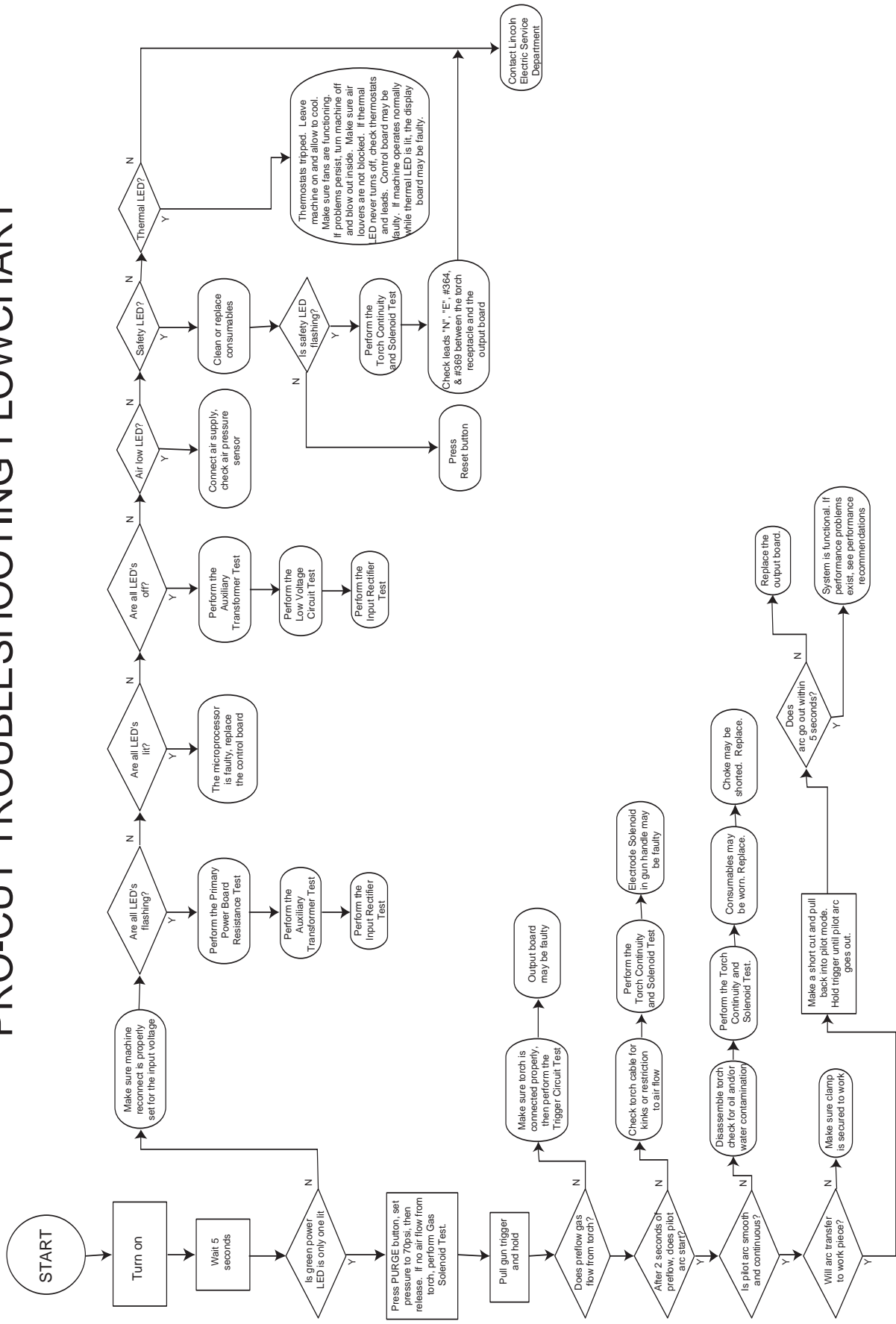

PRO-CUT 55



Return to Section TOC
Return to Master TOC

Return to Section TOC
Return to Master TOC

Return to Section TOC
Return to Master TOC

Return to Section TOC
Return to Master TOC

PRO-CUT 55



TROUBLESHOOTING & REPAIR

INPUT FILTER CAPACITOR DISCHARGE PROCEDURE

⚠ WARNING

Service and repair should be performed by only Lincoln Electric factory trained personnel. Unauthorized repairs performed on this equipment may result in danger to the technician or machine operator and will invalidate your factory warranty. For your safety and to avoid electrical shock, please observe all safety notes and precautions detailed throughout this manual.

If for any reason you do not understand the test procedures or are unable to perform the test/repairs safely, contact the Lincoln Electric Service Department for electrical troubleshooting assistance before you proceed. Call 1-888-935-3877.

DESCRIPTION

This procedure will drain off any charge stored in the two large capacitors that are part of the power board assembly. This procedure **MUST** be performed, as a safety precaution, before conducting any test or repair procedure that requires you to touch internal components of the machine.

MATERIALS NEEDED

- Volt/Ohmmeter (Multimeter)
- 5/16" Nut driver
- Insulated gloves
- Insulated pliers
- High wattage resistor - 25 to 1000 ohms, 25 watts minimum

PRO-CUT 55



INPUT FILTER CAPACITOR DISCHARGE PROCEDURE *(continued)*

⚠ WARNING

ELECTRIC SHOCK can kill.



- Have an electrician install and service this equipment.
- Turn the input power off at the fuse box before working on equipment.
- Do not touch electrically hot parts.
- Prior to performing preventative maintenance, perform the following capacitor discharge procedure to avoid electric shock.

DISCHARGE PROCEDURE

1. Turn off input power and disconnect input power lines.
2. Remove the 5/16" hex head screws from the wraparound machine cover.
3. Be careful not to make contact with the capacitor terminals located in the top and bottom of the Input Power Board.

4. Obtain a high resistance and high wattage resistor (25-1000 ohms and 25 watts minimum). This resistor is not supplied with machine. NEVER USE A SHORTING STRAP FOR THIS PROCEDURE.
5. Locate the four capacitor terminals (large hex head cap screws) shown in Figure F.1. One pair is at the top and one pair is at the bottom of the Power Board.
6. Use electrically insulated gloves and insulated pliers. Hold the body of the resistor and connect the resistor leads across the two capacitor terminals. Hold the resistor in place for 10 seconds. DO NOT TOUCH CAPACITOR TERMINALS WITH YOUR BARE HANDS.
7. Repeat the discharge procedure for the capacitor on the other two terminals.
8. Check the voltage across the terminals of all capacitors with a DC voltmeter. Polarity of the capacitor terminals is marked on the PC board above the terminals. Voltage should be zero. If any voltage remains, repeat this capacitor discharge procedure.

FIGURE F.1 – LOCATION OF INPUT FILTER CAPACITOR TERMINALS

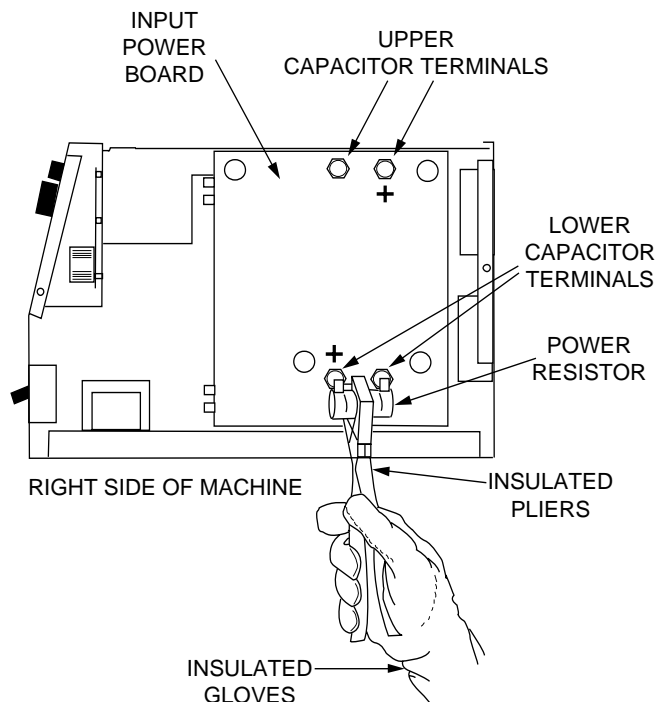

PRO-CUT 55

LINCOLN
ELECTRIC

TROUBLESHOOTING & REPAIR

INPUT RECTIFIER TEST

WARNING

Service and repair should be performed by only Lincoln Electric factory trained personnel. Unauthorized repairs performed on this equipment may result in danger to the technician or machine operator and will invalidate your factory warranty. For your safety and to avoid electrical shock, please observe all safety notes and precautions detailed throughout this manual.

If for any reason you do not understand the test procedures or are unable to perform the test/repairs safely, contact the Lincoln Electric Service Department for electrical troubleshooting assistance before you proceed. Call 1-888-935-3877.

DESCRIPTION

This test will help determine if the input rectifier has “shorted” or “open” diodes.

MATERIALS NEEDED

- Analog voltmeter/ohmmeter (multimeter)
- Phillips head screw driver
- Wiring diagram

PRO-CUT 55



TROUBLESHOOTING & REPAIR

INPUT RECTIFIER TEST *(continued)*

TEST PROCEDURE

1. Remove main input power to the machine.
2. Perform the **Input Filter Capacitor Discharge Procedure** detailed earlier in this section.
3. Locate the input rectifier (D1) and lead locations. See Figure F.2.
4. With the phillips head screw driver, remove leads #207, 207A and #209 from the rectifier.
5. Use the analog ohmmeter to perform the tests detailed in **Table F.1**. See the Wiring Diagram.

FIGURE F.2 – INPUT RECTIFIER AND LEADS

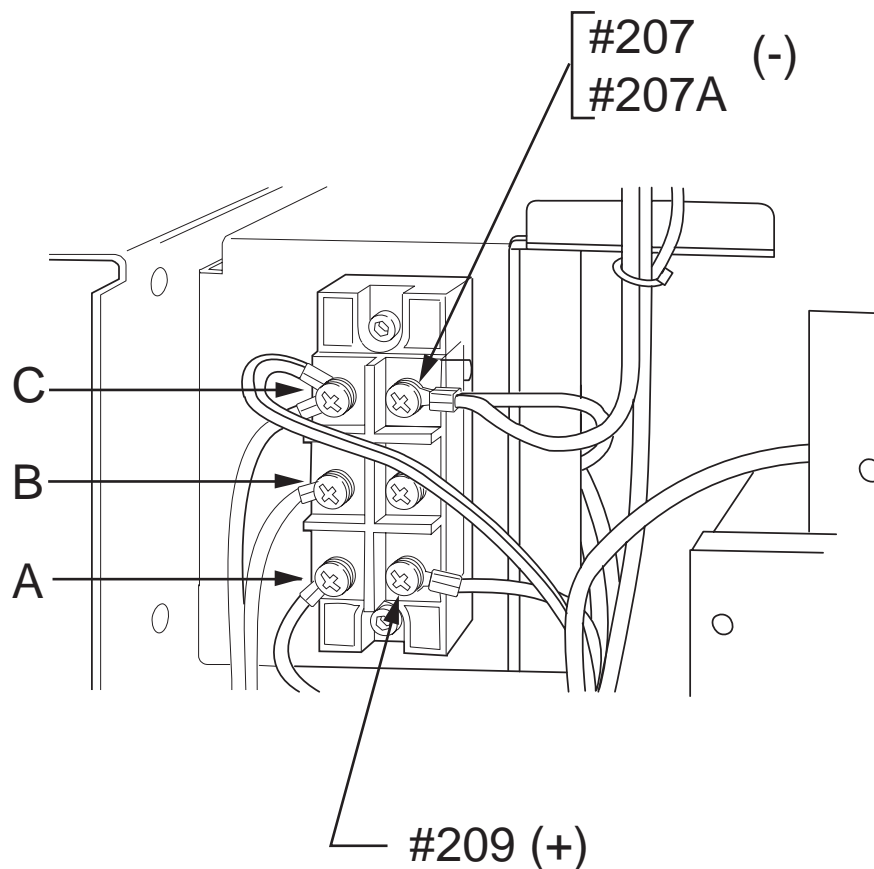

TROUBLESHOOTING & REPAIR

INPUT RECTIFIER TEST *(continued)*

TABLE F.1 INPUT RECTIFIER TEST POINTS

TEST POINT TERMINALS		ANALOG METER X10 RANGE
+ Probe	- Probe	Acceptable Meter Readings
A	207	Greater than 1000 ohms
B	207	Greater than 1000 ohms
C	207	Greater than 1000 ohms
A	209	Less than 100 ohms
B	209	Less than 100 ohms
C	209	Less than 100 ohms
207	A	Less than 100 ohms
207	B	Less than 100 ohms
207	C	Less than 100 ohms
209	A	Greater than 1000 ohms
209	B	Greater than 1000 ohms
209	C	Greater than 1000 ohms

6. If the input rectifier does not meet the acceptable readings outlined in Table F.1, the component may be faulty. Replace.

NOTE: Before replacing the input rectifier (D1) check the input power switch (S1) and perform the **Primary Power Board Resistance Test**. Also check for leaky or faulty filter capacitors.

7. If the input rectifier is good, be sure to reconnect leads #207, #207A and #209 to the correct terminals and torque to 31 in.-lbs. Apply a coating of Essex D-4-8 insulating compound.

8. If the input rectifier is faulty, see the **Input Rectifier Bridge Removal & Replacement** procedure. See the Wiring Diagram and **Figure F.2**.

Return to Section TOC
Return to Master TOC

Return to Section TOC
Return to Master TOC

Return to Section TOC
Return to Master TOC

Return to Section TOC
Return to Master TOC

PRO-CUT 55



TROUBLESHOOTING & REPAIR

PRIMARY POWER BOARD RESISTANCE TEST AND CAPACITOR VOLTAGE TEST

⚠ WARNING

Service and repair should be performed by only Lincoln Electric factory trained personnel. Unauthorized repairs performed on this equipment may result in danger to the technician or machine operator and will invalidate your factory warranty. For your safety and to avoid electrical shock, please observe all safety notes and precautions detailed throughout this manual.

If for any reason you do not understand the test procedures or are unable to perform the test/repairs safely, contact the Lincoln Electric Service Department for electrical troubleshooting assistance before you proceed. Call 1-888-935-3877.

DESCRIPTION

This test will determine if the primary power board has any “shorted” or “leaky” power diodes or Insulated Gate Bipolar Transistors (IGBTs). Also it will help to indicate any “shorted” input filter capacitors.

MATERIALS NEEDED

Analog voltmeter/ohmmeter (multimeter)
Wiring Diagram
7/16” Wrench

PRO-CUT 55



TROUBLESHOOTING & REPAIR

PRIMARY POWER BOARD RESISTANCE TEST AND CAPACITOR VOLTAGE TEST *(continued)*

FIGURE F.3 – PRIMARY POWER BOARD REMOVAL

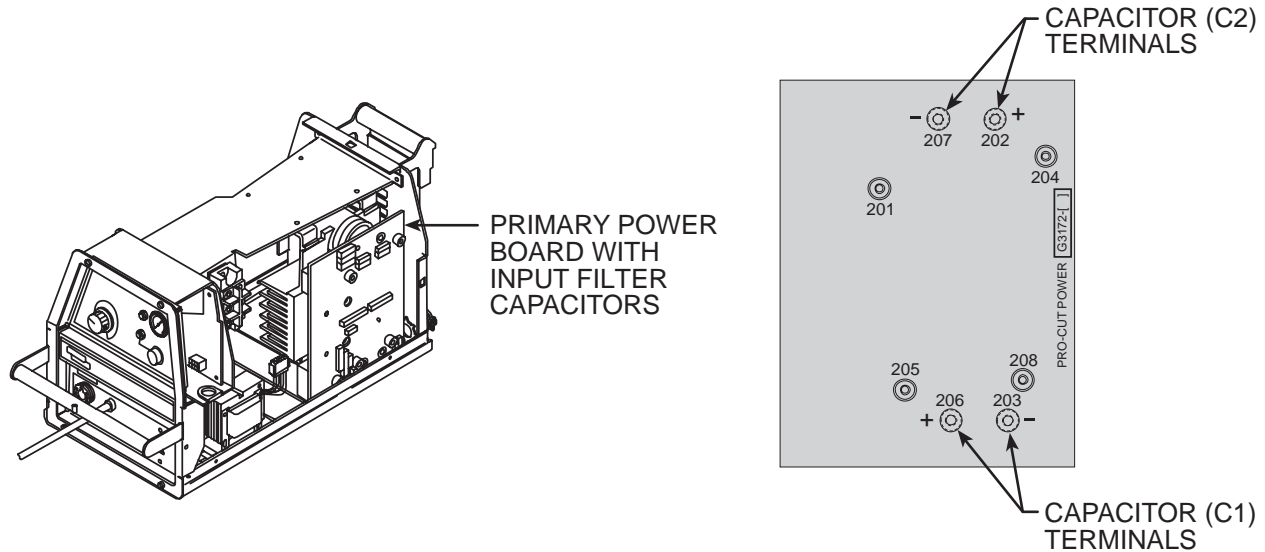

TEST PROCEDURE

1. Remove main input power to the Pro-Cut 55.
2. Perform the ***Input Filter Capacitor Discharge Procedure*** detailed earlier in this section.
3. Locate the primary power board and associated lead locations. See Figure F.3.
4. Carefully remove the main transformer primary leads #201, #204, #205 and #208 from the power board.
5. Use the analog ohmmeter to perform the test outlined in ***Table F.2***.

TROUBLESHOOTING & REPAIR

PRIMARY POWER BOARD RESISTANCE TEST AND CAPACITOR VOLTAGE TEST *(continued)*

TABLE F.2
PRIMARY POWER BOARD RESISTANCE TEST POINTS

TEST POINT TERMINALS		ANALOG METER X10 RANGE
+ Probe	- Probe	Acceptable Meter Readings
201 207A	207A 201	Greater than 1000 ohms Less than 100 ohms
204 207A	207A 204	Greater than 1000 ohms Less than 100 ohms
202A 204	204 202A	Greater than 1000 ohms Less than 100 ohms
202A 201	201 202A	Greater than 1000 ohms Less than 100 ohms
205 203A	203A 205	Greater than 1000 ohms Less than 100 ohms
208 203A	203A 208	Greater than 1000 ohms Less than 100 ohms
206 208	208 206	Greater than 1000 ohms Less than 100 ohms
206 205	205 206	Greater than 1000 ohms Less than 100 ohms

6. If the power board does not meet the acceptable readings outlined in Table F.2, the board is faulty. Replace. See **Power Board Removal and Replacement Procedure**.
 7. If the power board “passes” the resistance test, the IGBT portion of the board is good. However, other circuits on the power board may be faulty. These circuits are NOT readily tested or serviceable.
 8. Reconnect leads #201, #204, #205 and #208 to their appropriate terminals.
- NOTE:** Complete power board and filter capacitor replacement is recommended.

Return to Section TOC
Return to Master TOC
Return to Section TOC
Return to Master TOC
Return to Section TOC
Return to Master TOC
Return to Section TOC
Return to Master TOC

TROUBLESHOOTING & REPAIR

PRIMARY POWER BOARD RESISTANCE TEST AND CAPACITOR VOLTAGE TEST *(continued)*

CAPACITOR VOLTAGE TEST

This test will help the technician to determine if the input filter capacitors are being charged equally to the correct voltage levels.

NOTE: This test should only be conducted with the Pro-Cut 55 connected for 400 VAC and above, and with the appropriate input voltage applied.

TEST PROCEDURE

1. Remove main input power to the Pro-Cut 55.
2. Perform the ***Input Filter Capacitor Discharge Procedure*** detailed earlier in this section.
3. Locate and familiarize yourself with the capacitor test locations on the primary power board. See ***Figure F.3***.

4. The following tests will be performed with the input power applied to the Pro-Cut 55. ***BE CAREFUL. ALWAYS REMOVE THE INPUT POWER AND PERFORM THE INPUT FILTER CAPACITOR DISCHARGE PROCEDURE BEFORE TOUCHING ANY MACHINE COMPONENT.***

WARNING

ELECTRIC SHOCK can kill.



- Have an electrician install and service this equipment.
- Turn the input power off at the fuse box before working on equipment.
- Do not touch electrically hot parts.

-
5. Apply the correct input power[†] and turn ON the Pro-Cut 55.

[†] **NOTE:** This test should only be conducted with the Pro-Cut 55 reconnect switch and “A” jumper configured for 400 VAC and above.

TROUBLESHOOTING & REPAIR

PRIMARY POWER BOARD RESISTANCE TEST AND CAPACITOR VOLTAGE TEST *(continued)*

6. Check for the appropriate voltages outlined in Table F.3.

NOTE: Voltages may vary with the input line voltage.

NOTE: If the capacitor voltage is too high (over 400 VDC) or too low (less than 220 VDC) the control board will deactivate relay CR1. This will prevent output.

7. If the test voltages do not meet the expected values as listed in Table F.3, the capacitors or other components on the power board may be faulty. Replace.

NOTE: If the capacitor voltages are NOT balanced within 20 VDC, the capacitors may need “conditioning.” See the **Maintenance** section.

TABLE F.3 - CAPACITOR VOLTAGES

INPUT APPLIED	EXPECTED VOLTS DC AT CAPACITOR TERMINALS
460VAC	325VDC
440VAC	311VDC
415VAC	293VDC
380VAC	269VDC

NOTE: If Capacitor C1 is found to be defective, both Capacitors C1 and C2 must be replaced at the same time. The capacitors must be replaced in matched sets.

Return to Section TOC
Return to Master TOC

NOTES

Return to Section TOC
Return to Master TOC

Return to Section TOC
Return to Master TOC

Return to Section TOC
Return to Master TOC

Return to Section TOC
Return to Master TOC

PRO-CUT 55



TROUBLESHOOTING & REPAIR

OUTPUT POWER BOARD RESISTANCE TEST

WARNING

Service and repair should be performed by only Lincoln Electric factory trained personnel. Unauthorized repairs performed on this equipment may result in danger to the technician or machine operator and will invalidate your factory warranty. For your safety and to avoid electrical shock, please observe all safety notes and precautions detailed throughout this manual.

If for any reason you do not understand the test procedures or are unable to perform the test/repairs safely, contact the Lincoln Electric Service Department for electrical troubleshooting assistance before you proceed. Call 1-888-935-3877.

DESCRIPTION

This test will help the technician determine if the output power board is faulty.

MATERIALS NEEDED

5/16" Nut driver
Analog Volt/ohmmeter
7/16" Wrench

PRO-CUT 55



TROUBLESHOOTING & REPAIR

OUTPUT POWER BOARD RESISTANCE TEST (continued)

FIGURE F.4 – OUTPUT POWER BOARD LEAD LOCATIONS

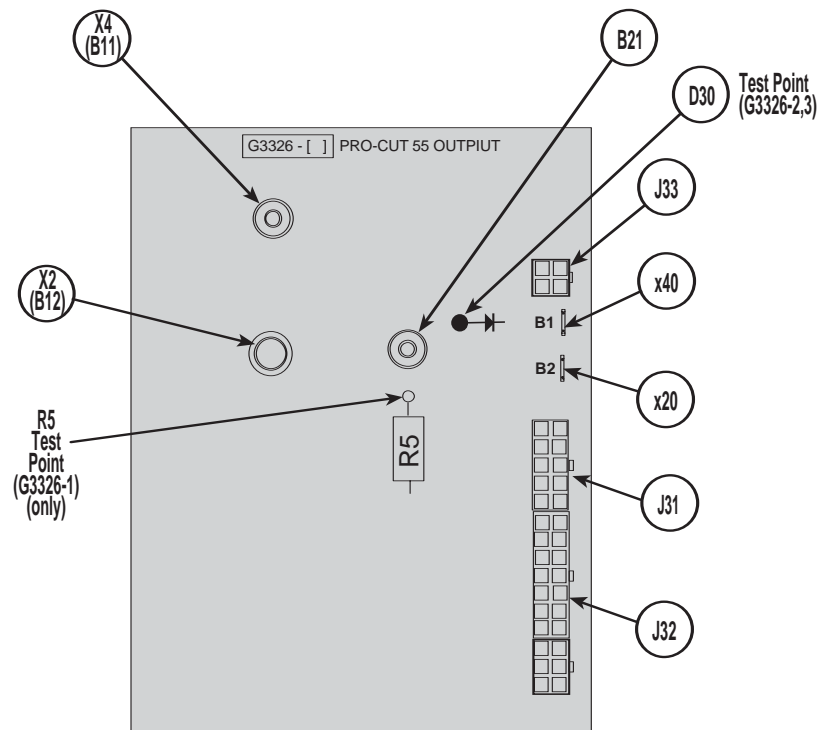

TEST PROCEDURE

1. Remove input power to the Pro-Cut 55 machine.
2. Perform the **Input Filter Capacitor Discharge Procedure** detailed earlier in this section.
3. Remove the torch assembly from the machine.
4. Remove leads X4, X2, B21, X20, X40 and plugs J33 and J32 from the output power board. See Figure F.4.
5. Using the analog ohmmeter, perform the resistance checks per **Table F.4**.

PRO-CUT 55



TROUBLESHOOTING & REPAIR

OUTPUT POWER BOARD RESISTANCE TEST *(continued)*

TABLE F.4 - OUTPUT POWER BOARD RESISTANCE

TEST POINTS	CIRCUIT OR COMPONENT(S) BEING TESTED	EXPECTED RESISTANCE
+Probe J33-Pin4 to -Probe Terminal B11	Diode A1 and associated trace	Less than 100 ohms
+Probe Terminal B11 to -Probe J33-Pin4	Diode A1 and associated trace	Greater than 1000 ohms
+Probe J33-Pin4 to -Probe Terminal B12	Diode A1 and associated trace	Less than 100 ohms
+Probe Terminal B12 to -Probe J33-Pin4	Diode A1 and associated trace	Greater than 1000 ohms
or D30 +Probe R5 Test Point to -Probe Terminal B1	Diode A2 and associated trace	Less than 100 ohms
+Probe Terminal B1 to -Probe R5 Test Point or -Probe D30 Test Point	Diode A2 and associated trace	Greater than 1000 ohms
or D30 +Probe R5 Test Point to -Probe Terminal B2	Diode A2 and associated trace	Less than 100 ohms
+Probe Terminal B2 to -Probe R5 Test Point or -Probe D30 Test Point	Diode A2 and associated trace	Greater than 1000 ohms
+Probe R5 Test Point to -Probe J32-Pin14	Transistor A2 and associated trace	Less than 100 ohms
+Probe J32-Pin14 to -Probe R5 Test Point or -Probe D30 Test Point	Transistor A2 and associated trace	Greater than 1000 ohms

6. If any of the resistance checks are not correct, the output power board is faulty. Replace. See the **Output Power Board Removal and Replacement Procedure**. Note: Use D30 test point for boards G3326-2,3.

7. If the output power board “passes” the resistance

test, the power diode and transistor portion of the board is good. However, other circuits on the power board may be faulty. These circuits are NOT readily tested or serviceable.

8. Reconnect the leads and plugs previously removed.

PRO-CUT 55



NOTES

Return to Section TOC
Return to Master TOC

Return to Section TOC
Return to Master TOC

Return to Section TOC
Return to Master TOC

Return to Section TOC
Return to Master TOC

PRO-CUT 55



TROUBLESHOOTING & REPAIR

TORCH CONTINUITY AND SOLENOID TEST

⚠ WARNING

Service and repair should be performed by only Lincoln Electric factory trained personnel. Unauthorized repairs performed on this equipment may result in danger to the technician or machine operator and will invalidate your factory warranty. For your safety and to avoid electrical shock, please observe all safety notes and precautions detailed throughout this manual.

If for any reason you do not understand the test procedures or are unable to perform the test/repairs safely, contact the Lincoln Electric Service Department for electrical troubleshooting assistance before you proceed. Call 1-888-935-3877.

DESCRIPTION

This procedure will help the technician determine if the torch cable, consumables and electrode solenoid are functioning properly.

MATERIALS NEEDED

5/16" Nut driver
Volt/ohmmeter
12 VDC @ 1 Amp Power Supply

PRO-CUT 55



TROUBLESHOOTING & REPAIR

TORCH CONTINUITY AND SOLENOID TEST *(continued)*

FIGURE F.5 - TORCH CONNECTOR - MACHINE END

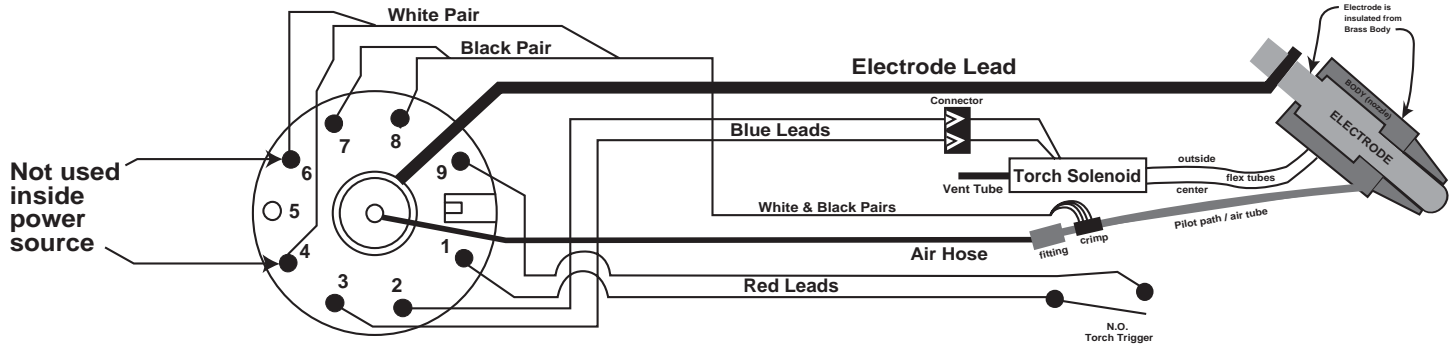

TEST PROCEDURE

1. Remove input power to the Pro-Cut 55 machine.
2. Remove the torch assembly from the machine.

3. Using the ohmmeter, check the torch resistances per Table F.5.

NOTE: Take the “Pin” test point measurements at the machine end of the torch assembly. See Figure F.5.

Return to Section TOC
Return to Master TOC

TROUBLESHOOTING & REPAIR

TORCH CONTINUITY AND SOLENOID TEST *(continued)*

TABLE F.5 - TORCH ASSEMBLY RESISTANCES

TEST POINTS	CIRCUIT(S) BEING TESTED	EXPECTED RESISTANCE	TEST CONDITIONS
Pin 7 to Pin 8	Parallel pilot arc leads	1.5 ohms maximum	None
Pin 7 to Torch Nozzle	One pilot arc lead to nozzle	1.0 ohm maximum	Torch consumables in place
Pin 8 to Torch Nozzle	One pilot arc lead to nozzle	1.0 ohm maximum	Torch consumables in place
Pin 1 to Pin 9	Torch trigger circuit	100K ohms minimum	Torch trigger NOT pulled (not activated)
Pin 1 to Pin 9	Torch trigger circuit	1.0 ohm maximum	Torch trigger pulled (activated)
Pin 2 to Pin 3	Electrode Solenoid	45 to 55 ohms	None
Pin 7 to Torch Electrode at machine end of torch	Pilot and Electrode circuit	1.0 ohm maximum	Torch consumables in place
Pin 8 to Torch Electrode at machine end of torch	Pilot and Electrode circuit	1.0 ohm maximum	Torch consumables in place
Pin 7 To Pin 1 Pin 2 Pin 3 Pin 9	Electrical Isolation of Circuits	Open (very high)	Torch Consumables Removed
Pin 8 To Pin 1 Pin 2 Pin 3 Pin 9	Electrical Isolation of Circuits	Open (very high)	Torch Consumables Removed
Pins 1 & 9 to all other pins	Electrical Isolation of Torch Trigger Circuit	Open (very high)	None
Pins 2 & 3 to all other pins	Electrical Isolation of Torch Solenoid Circuit	Open (very high)	None

- If any of the resistance checks are not correct, the torch assembly may be faulty. Repair or replace.
- Carefully apply the 12 VDC supply to the electrode solenoid. (positive to Pin 2 and negative to Pin 3). The electrode solenoid should activate. Listen for the solenoid action in the torch handle. If the solenoid does not activate, it may be faulty. Replace.

PRO-CUT 55

Return to Section TOC
Return to Master TOC

Return to Section TOC
Return to Master TOC

Return to Section TOC
Return to Master TOC

Return to Section TOC
Return to Master TOC

PRO-CUT 55



TROUBLESHOOTING & REPAIR

AIR/GAS SOLENOID TEST

WARNING

Service and repair should be performed by only Lincoln Electric factory trained personnel. Unauthorized repairs performed on this equipment may result in danger to the technician or machine operator and will invalidate your factory warranty. For your safety and to avoid electrical shock, please observe all safety notes and precautions detailed throughout this manual.

If for any reason you do not understand the test procedures or are unable to perform the test/repairs safely, contact the Lincoln Electric Service Department for electrical troubleshooting assistance before you proceed. Call 1-888-935-3877.

DESCRIPTION

This procedure will help the technician determine if the solenoid is functioning properly.

MATERIALS NEEDED

5/16" Nut driver
12 VDC @ 3 amp supply
Volt/ohmmeter

PRO-CUT 55



TROUBLESHOOTING & REPAIR

AIR/GAS SOLENOID TEST (continued)

FIGURE F.6 – AIR SOLENOID

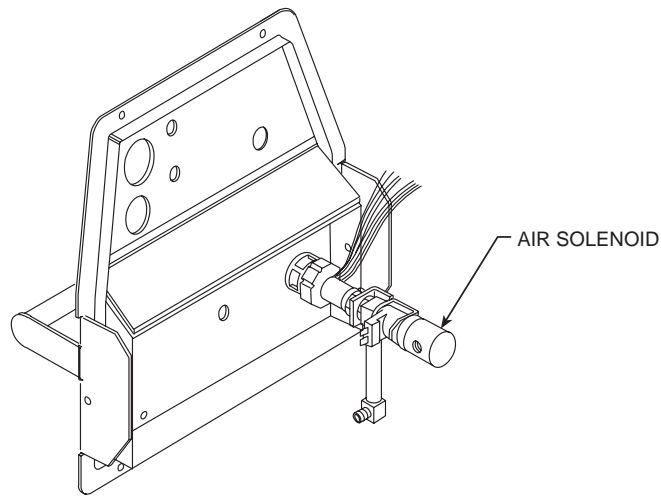

TEST PROCEDURE

1. Remove input power to the machine.
2. Perform the **Input Capacitor Discharge Procedure** detailed earlier in this section.
3. Locate the air solenoid and leads. See Figure F.6.
4. Carefully remove plug J31 from the output power board. See Figure F.7.
5. Check the coil resistance of the solenoid at plug J31 pin-6 to J31 pin-5. Normal resistance is approximately 20 ohms. If the resistance is abnormal, check the continuity (zero or very low resistance) of leads #366 and #361 between the solenoid and plug J31.
6. Carefully apply the 12 VDC supply to the solenoid leads at plug J31 (positive to J31 pin-6 lead #366 and negative to J31 pin-5 lead #361).
7. Install plug J31 back into the output power board.

See the Wiring Diagram. If the leads are good, the solenoid coil may be faulty.

With proper air pressure applied, the solenoid should activate and air should flow.

If the solenoid activates but air does not flow, check for a restriction in the air line.

FIGURE F.7 – PLUG J31 LOCATION

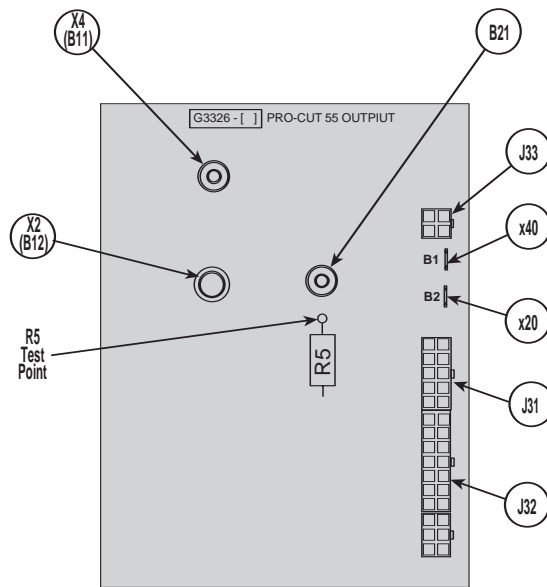

PRO-CUT 55



Return to Section TOC
Return to Master TOC
Return to Section TOC
Return to Master TOC
Return to Section TOC
Return to Master TOC
Return to Section TOC
Return to Master TOC

TROUBLESHOOTING & REPAIR

(T2) AUXILIARY TRANSFORMER TEST

⚠ WARNING

Service and repair should be performed by only Lincoln Electric factory trained personnel. Unauthorized repairs performed on this equipment may result in danger to the technician or machine operator and will invalidate your factory warranty. For your safety and to avoid electrical shock, please observe all safety notes and precautions detailed throughout this manual.

If for any reason you do not understand the test procedures or are unable to perform the test/repairs safely, contact the Lincoln Electric Service Department for electrical troubleshooting assistance before you proceed. Call 1-888-935-3877.

DESCRIPTION

The test will determine if the auxiliary transformer is functional when the correct primary voltage is applied to the primary winding.

MATERIALS NEEDED

- Volt/ohmmeter
- Machine wiring diagram
- 5/16" Nut driver
- 230 VAC isolated power supply

TROUBLESHOOTING & REPAIR

(T2) AUXILIARY TRANSFORMER TEST (*continued*)

FIGURE F.8 – T2 AUXILIARY TRANSFORMER

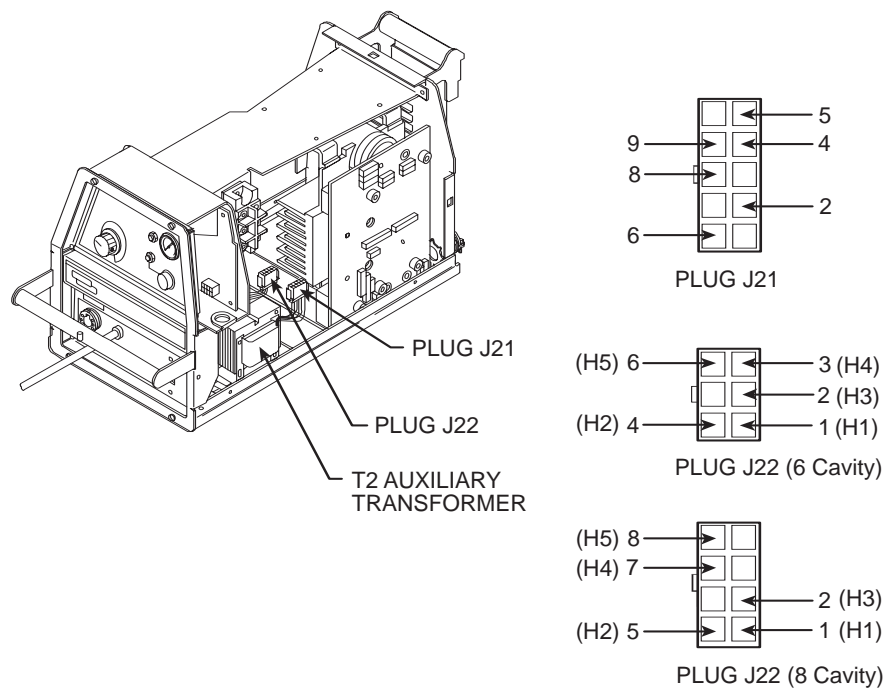

PROCEDURE

1. Remove main input power to the Pro-Cut 55 machine.
2. Perform the **Input Filter Capacitor Discharge Procedure** detailed earlier in this section.
3. Locate the auxiliary transformer just behind the input line switch on the lower right side of the machine.
4. Locate and disconnect plugs J21 and J22 from the wiring harness. Cut any necessary cable ties. See Figure F.8.
5. Carefully apply the 230 VAC isolated supply to leads H1 (1J22) and H3 (2J22) of the auxiliary transformer. These leads are located in plug J22.
6. Carefully check for the presence of the following primary and secondary voltages at the appropriate leads at plugs J21 and J22. See Figure F.8 and **Table F.6.**

TROUBLESHOOTING & REPAIR

(T2) AUXILIARY TRANSFORMER TEST *(continued)*

TABLE F.6 - J21 AND J22 (6 Pin) VOLTAGES

TEST POINT	TEST POINT	EXPECTED VOLTAGE
H1 (1J22)	H2 (4J22)	200 - 208VAC
H1 (1J22)	H4 (3J22)	380 - 415VAC
H1 (1J22)	H5 (6J22)	440 - 460VAC
Brown (8J21)	Brown (3J21)	12VAC
Red (2J21)	Red (6J21)	24VAC
Blue (9J21)	White (5J21)	18VAC
Blue (4J21)	White (5J21)	18VAC

J21 AND J22 (8 Pin) VOLTAGES

TEST POINT	TEST POINT	EXPECTED VOLTAGE
H1 (1J22)	H2 (5J22)	200 - 208VAC
H1 (1J22)	H4 (7J22)	380 - 415VAC
H1 (1J22)	H5 (8J22)	440 - 460VAC
H1 (1J22)	H6 (4J22)	560 - 600VAC
Brown (8J21)	Brown (3J21)	12VAC
Red (2J21)	Red (6J21)	24VAC
Blue (9J21)	White (5J21)	18VAC
Blue (4J21)	White (5J21)	18VAC

7. If the correct test voltages are present, the auxiliary transformer is good.
 8. If any of the voltages are missing or very low with the proper primary voltage applied, the auxiliary transformer may be faulty.
 9. If the auxiliary transformer tests good but it does not function when connected to the Pro-Cut 55, check the harness wiring to the auxiliary transformer. See the Wiring Diagram.
 10. When finished with the test, replace plugs 21 and 22 and the case wraparound.
- NOTE:** There should not be continuity between the isolated windings. With the input power removed from the transformer, check the windings using the table below.

TEST POINT	TEST POINT	EXPECTED RESISTANCE
H1	Brown Lead	Greater than 100 K ohms
H1	Red Lead	Greater than 100 K ohms
H1	Blue/White Leads	Greater than 100 K ohms
Brown Leads	Red Leads	Greater than 100 K ohms
Brown Leads	Blue/White Leads	Greater than 100 K ohms
Red Leads	Blue/White Leads	Greater than 100 K ohms

Return to Section TOC

Return to Master TOC

Return to Section TOC

Return to Master TOC

Return to Section TOC

Return to Master TOC

Return to Section TOC

Return to Master TOC

Return to Section TOC
Return to Master TOC

Return to Section TOC
Return to Master TOC

Return to Section TOC
Return to Master TOC

Return to Section TOC
Return to Master TOC

PRO-CUT 55



TROUBLESHOOTING & REPAIR

TRIGGER CIRCUIT TEST

WARNING

Service and repair should be performed by only Lincoln Electric factory trained personnel. Unauthorized repairs performed on this equipment may result in danger to the technician or machine operator and will invalidate your factory warranty. For your safety and to avoid electrical shock, please observe all safety notes and precautions detailed throughout this manual.

If for any reason you do not understand the test procedures or are unable to perform the test/repairs safely, contact the Lincoln Electric Service Department for electrical troubleshooting assistance before you proceed. Call 1-888-935-3877.

DESCRIPTION

The procedure will help the technician determine if there is a problem or “fault” in the internal trigger circuit.

MATERIALS NEEDED

- Ohmmeter/voltmeter (multimeter)
- 5/16” Nut driver
- Simplified Trigger Circuit Diagram

PRO-CUT 55



TRIGGER CIRCUIT TEST (continued)

FIGURE F.9 – SIMPLIFIED TRIGGER CIRCUIT DIAGRAM (Later Versions)

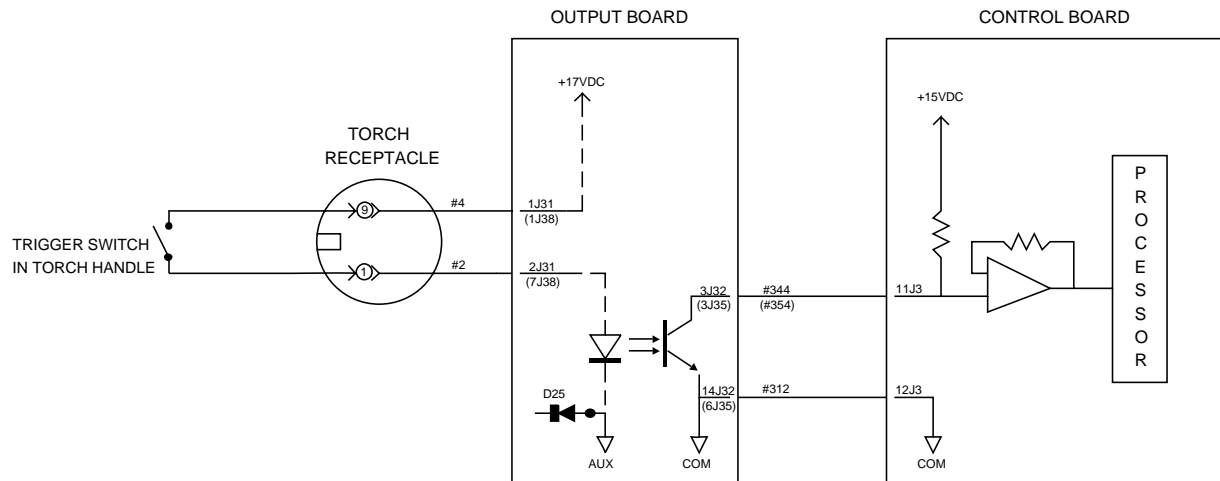

PROCEDURE

1. Remove input power to the Pro-Cut 55 machine.
2. Perform the **Input Filter Capacitor Discharge Procedure** detailed earlier in this section.
3. Locate the torch cable receptacle and leads #2 and #4. See Figure F.9, the Simplified Trigger Circuit Diagram. These leads are best accessed at plug J31 on the output board. See **Figure F.10**.
4. Using the ohmmeter, check for continuity (less than one ohm) from lead #2 to lead #4. The torch trigger must be pulled and all input power removed from the machine. If continuity (less than one ohm) is **not** read, check the leads from plug J31 to the torch cable receptacle. Perform the **Torch Continuity and Solenoid Test**.
5. If less than one ohm is read (only when the torch trigger is pulled), proceed to the next step. Also see **Output Board LED Definitions** and related figures.
6. Apply the correct input power to the Pro-Cut 55. Carefully check for approximately 17 VDC from plug J31 pin-1(lead#4) (positive) to plug J31 pin-2 (lead#2) (negative). See **Figure F.10**. If the correct voltage is not present, perform the **Low Voltage Circuit Test**. Also see **Output Board LED Definitions** and related figures.
7. If the correct voltage is present in Step 6, carefully check for the presence of approximately 15 VDC from plug J32 pin-3 (lead#344) (positive) to plug J32 pin-14 (lead#312) (negative). See **Figure F.10**. Also see **Control Board LED Definitions** and related figures. If the correct voltage is not present, perform the **Low Voltage Circuit Test**.
8. If the correct voltage is present in the above test, carefully pull the torch trigger.

 **WARNING**

PILOT ARC, CUTTING ARC, AND HIGH VOLTAGE MAY BE PRESENT AT THE TORCH HEAD. Perform this test with the air input removed to avoid a pilot arc at the torch.



TROUBLESHOOTING & REPAIR

TRIGGER CIRCUIT TEST *(continued)*

9. With the torch trigger activated check the voltage at plug J32 pin-3 (lead#344) (positive) to plug J32 pin-14 (lead#312) (negative). Normal is less than 1 VDC. If more than 1 VDC is indicated, the power output board may be faulty. Release (deactivate) the torch trigger and remove input power to the Pro-Cut 55.
10. Perform the ***Input Filter Capacitor Discharge Procedure***.
11. Check the continuity of leads #344 and #312 between the output board and the control board. See ***Figure F.9***, the ***Simplified Trigger Circuit Diagram***, and ***Figure F.10***.
12. If all of the above checks are OK, the control board may be faulty. Replace.

Return to Section TOC

Return to Master TOC

Return to Section TOC

Return to Master TOC

Return to Section TOC

Return to Master TOC

Return to Section TOC

Return to Master TOC

PRO-CUT 55



TRIGGER CIRCUIT TEST (continued)

FIGURE F.10 - OUTPUT BOARD TRIGGER CIRCUIT TEST POINTS AND LEADS

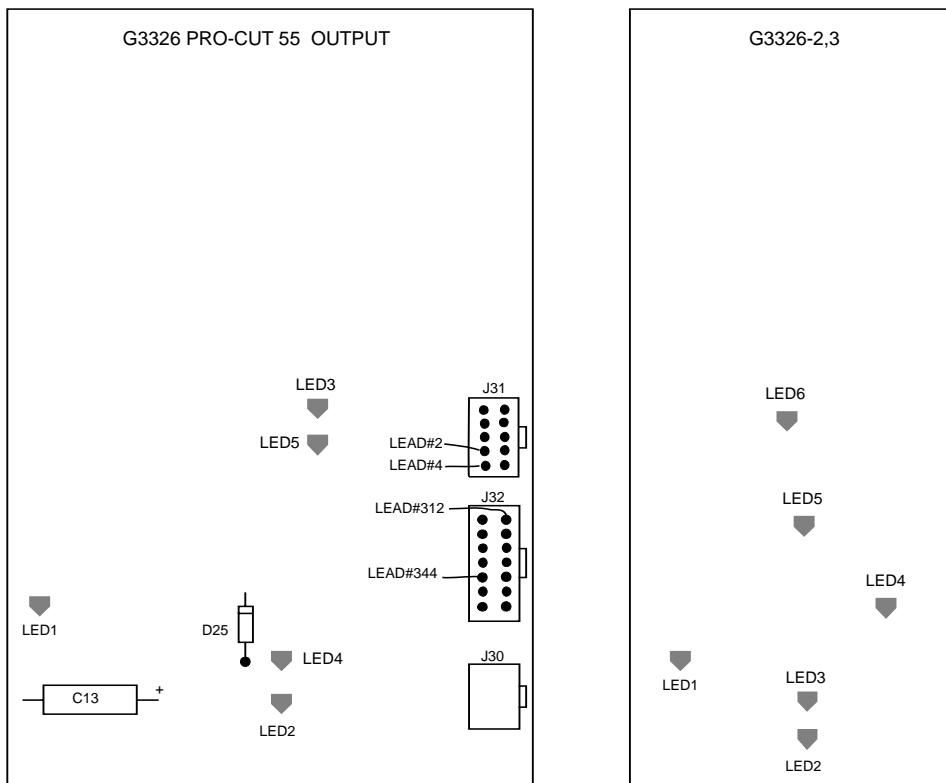

PRO-CUT 55 OUTPUT BOARD LED DEFINITIONS

LED1: (Red) This light indicates that 24 VAC is being supplied to the output board from the auxiliary transformer. It also shows that the 24 VAC is being rectified to approximately 28 VDC. This DC voltage is used for the "parts-in-place" check for the torch circuit.

LED2: (Red) This light indicates that 12 VAC is being supplied to the output board from the auxiliary transformer. It also shows that the 12 VAC is being rectified to approximately 17 VDC. This DC voltage is used to power the trigger circuit and solenoid driver circuits incorporated on the output board.

LED3: (Green) This light indicates that the air solenoid driver circuit is functioning. When this LED is lit, the air solenoid should be activated.

LED4: (Green) This light indicates that the trigger circuit on the output board has been activated. This LED should be lit when the torch or remote trigger is closed. This trigger circuit, on the output board, then sends a signal to the control board.

LED5: (Green) This light indicates that the electrode solenoid driver circuit is functioning. When this light is lit, the electrode solenoid should be activated. The electrode solenoid should be energized during gas (air) pre-flow time. During pilot and cutting arc periods, the LED should be off. When the arc goes out, the machine enters the post-flow state. Two seconds after the start of post-flow the electrode solenoid is activated a few times. The LED should blink to indicate this activity. The electrode solenoid will then be energized for the duration of post-flow. (The LED should be on.)

LED6: (Green) Indicates gate drive for pilot transistor.

PRO-CUT 55



TROUBLESHOOTING & REPAIR

TRIGGER CIRCUIT TEST *(continued)*

FIGURE F.11 - CONTROL BOARD LEDs

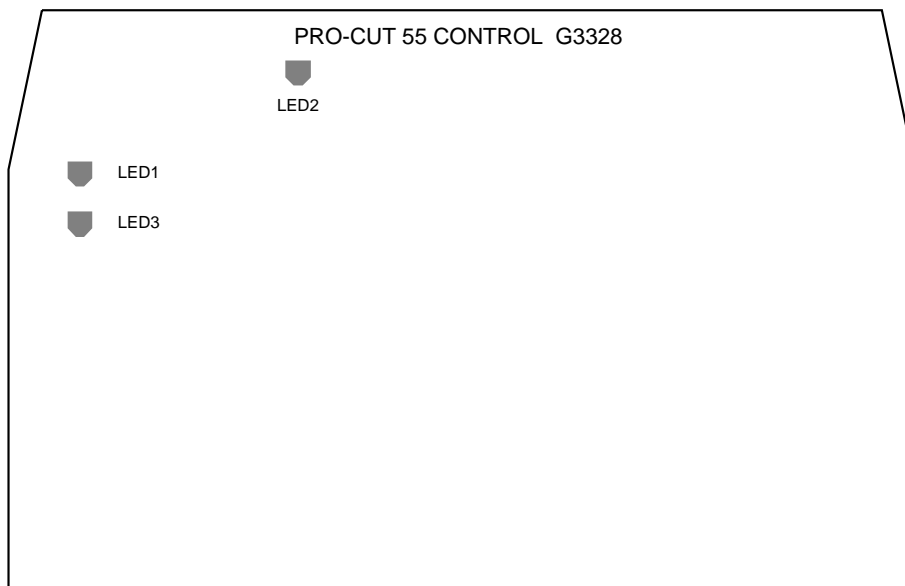

CONTROL BOARD LED DEFINITIONS

LED1: (Red) This light indicates that 18 VAC is being supplied to the control board from the auxiliary transformer. It also shows that the 18 VAC is being rectified and should be regulated to +15 VDC. This +15 VDC supply is used to power the circuitry on the control board.

LED2: (Red) This light indicates that the +5.5 VDC is present. This voltage is derived from the +15 VDC supply. The +5.5 VDC supply is used to power the circuitry on the control board.

LED3: (Red) This light indicates that 18 VAC is being supplied to the control board from the auxiliary transformer. It also shows that the 18 VAC is being rectified and should be regulated to -15 VDC. This -15 VDC supply is used to power the circuitry on the control board.

PRO-CUT 55



Return to Section TOC
Return to Master TOC

Return to Section TOC
Return to Master TOC

Return to Section TOC
Return to Master TOC

Return to Section TOC
Return to Master TOC

PRO-CUT 55



TROUBLESHOOTING & REPAIR

LOW VOLTAGE CIRCUIT TEST

WARNING

Service and repair should be performed by only Lincoln Electric factory trained personnel. Unauthorized repairs performed on this equipment may result in danger to the technician or machine operator and will invalidate your factory warranty. For your safety and to avoid electrical shock, please observe all safety notes and precautions detailed throughout this manual.

If for any reason you do not understand the test procedures or are unable to perform the test/repairs safely, contact the Lincoln Electric Service Department for electrical troubleshooting assistance before you proceed. Call 1-888-935-3877.

DESCRIPTION

These voltage checks will help the technician determine if the correct voltages are being applied and processed by the various P.C. boards. Some of the voltage verification test points are not easily accessible. The presence of these voltages can also be confirmed by LEDs on the various P.C. boards.

MATERIALS NEEDED

5/16" Nut driver
Volt/ohmmeter (multimeter)

PRO-CUT 55



TROUBLESHOOTING & REPAIR

LOW VOLTAGE CIRCUIT TEST (continued)

FIGURE F.12 - LOW VOLTAGE CIRCUIT DIAGRAM

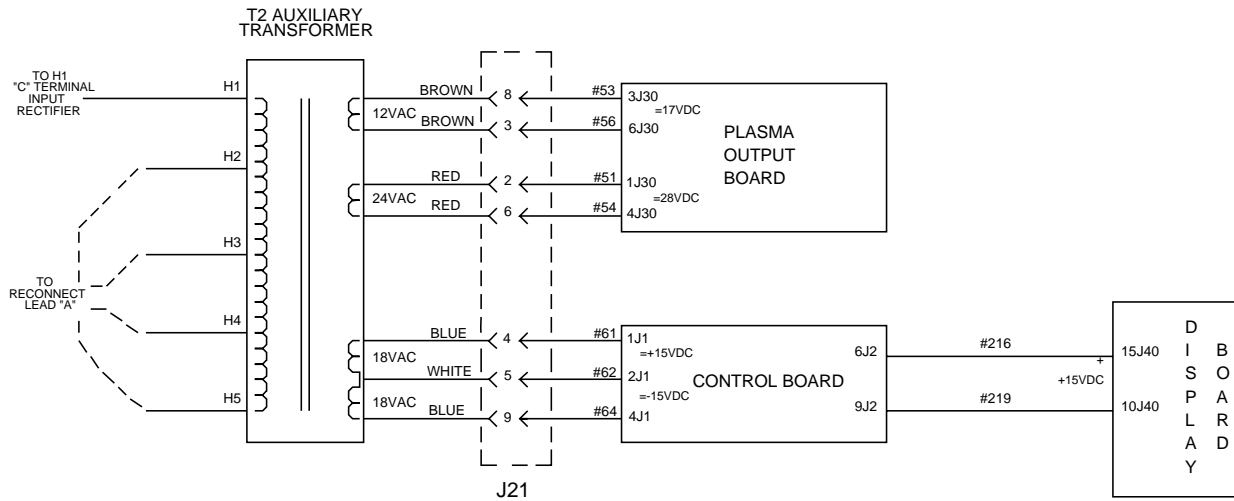

PROCEDURE

1. Remove input power to the Pro-Cut 55 machine.
2. Using the 5/16" nutdriver remove the case wraparound cover.

⚠ WARNING

ELECTRIC SHOCK can kill.



- Do not touch electrically hot parts.

3. Apply the correct input power to the machine and carefully check for the following voltages.
4. Check for the presence of approximately 28 VDC on the output board.
 - a. LED1 should be lit when 28 VDC is present. See **Figure F.13**. See **Output Board LED Definitions** and Figure F.12, Low Voltage Circuit Diagram.
 - b. To verify the presence of 28 VDC, check across capacitor C13. Make certain the voltmeter probes make good contact with the capacitor leads. See **Figure F.13**.

5. Check for the presence of 17 VDC on the output board.
 - a. LED2 should be lit when 17 VDC is present. See **Figure F.13**. See **Output Board LED Definitions** and Figure F.12, Low Voltage Circuit Diagram.
 - b. To verify the presence of 17 VDC, check from plug J31 Pin-6 to diode D25 (anode). See **Figure F.13**. Make certain the voltmeter probes make good contact with pin-6 and the diode anode lead.
6. Check for the presence of +15 VDC on the control board.
 - a. LED1 should be lit when +15 VDC is present. See **Figure F.13**. See **Control Board LED Definitions** and Figure F.12, Low Voltage Circuit Diagram.
7. Check for the presence of -15 VDC on the control board.
 - a. LED3 should be lit when -15 VDC is present. See **Figure F.13**. See **Control Board LED Definitions** and Figure F.12, Low Voltage Circuit Diagram.

Return to Section TOC | Return to Master TOC

TROUBLESHOOTING & REPAIR

8. Check for the presence of +5 VDC on the control board.
 - a. LED2 should be lit when +5 VDC is present. See **Figure F.14**. See **Control Board LED Definitions** and **Figure F.12, Low Voltage Circuit Diagram**.
9. Check for the presence of +15 VDC being applied to the display board from the control board. You may have to remove the display board to check it.
 - a. +15 VDC should be present at leads #216(+) to #219(-). See **Figure F.15** and **Figure F.12, Low Voltage Circuit Diagram**.
10. If any of the DC supply voltages are incorrect or missing, make certain the correct AC supply voltages are being applied to the P.C. boards. See **Figure F.12, Low Voltage Circuit Diagram** and **(T2) Auxiliary Transformer Test**.
11. When the test is complete, remove input power and replace the case wraparound cover.

TROUBLESHOOTING & REPAIR

LOW VOLTAGE CIRCUIT TEST (continued)

FIGURE F.13 – OUTBOARD LOW VOLTAGE CIRCUIT TEST POINTS AND LEDs

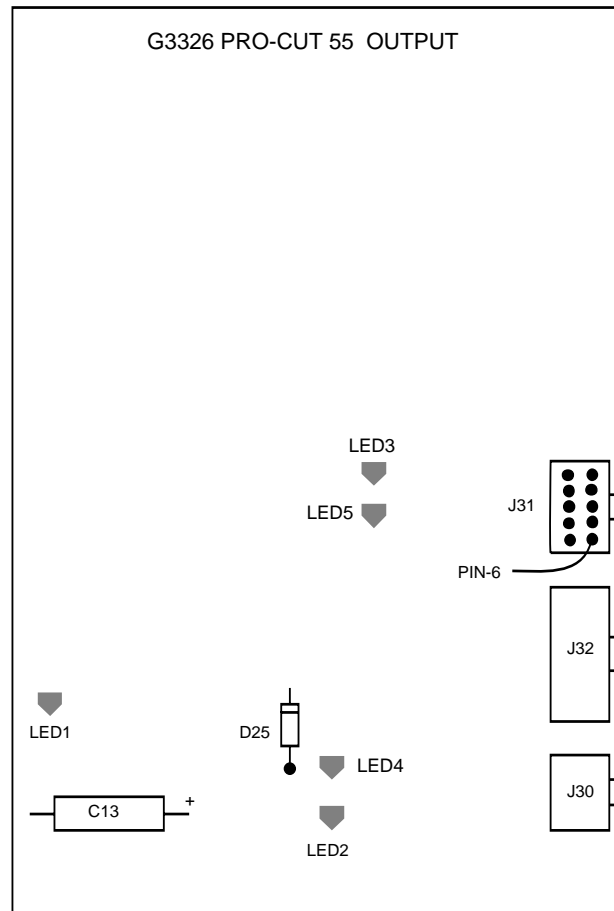

PRO-CUT 55 OUTPUT BOARD LED DEFINITIONS

LED1: (Red) This light indicates that 24 VAC is being supplied to the output board from the auxiliary transformer. It also shows that the 24 VAC is being rectified to approximately 28 VDC. This DC voltage is used for the "parts-in-place" check for the torch circuit.

LED2: (Red) This light indicates that 12 VAC is being supplied to the output board from the auxiliary transformer. It also shows that the 12 VAC is being rectified to approximately 17 VDC. This DC voltage is used to power the trigger circuit and solenoid driver circuits incorporated on the output board.

LED3: (Green) This light indicates that the air solenoid driver circuit is functioning. When this LED is lit, the air solenoid should be activated.

LED4: (Green) This light indicates that the trigger circuit on the output board has been activated. This LED should be lit when the torch or remote trigger is closed. This trigger circuit, on the output board, then sends a signal to the control board.

LED5: (Green) This light indicates that the electrode solenoid driver circuit is functioning. When this light is lit, the electrode solenoid should be activated. The electrode solenoid should be energized during gas (air) pre-flow time. During pilot and cutting arc periods, the LED should be off. When the arc goes out, the machine enters the post-flow state. Two seconds after the start of post-flow the electrode solenoid is activated a few times. The LED should blink to indicate this activity. The electrode solenoid will then be energized for the duration of post-flow. (The LED should be on).

PRO-CUT 55



TROUBLESHOOTING & REPAIR

LOW VOLTAGE CIRCUIT TEST *(continued)*

FIGURE F.14 – CONTROL BOARD LEDs

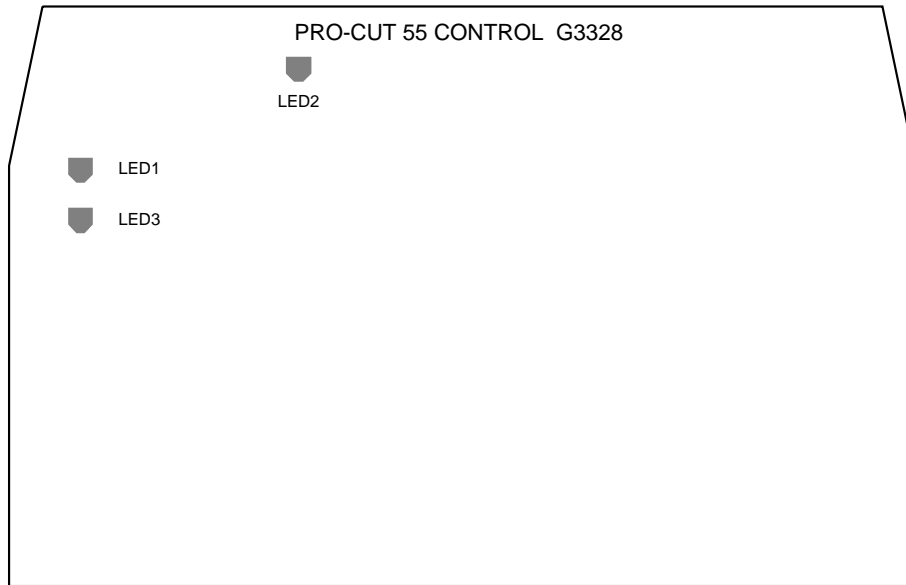

CONTROL BOARD LED DEFINITIONS

LED1: (Red) This light indicates that 18 VAC is being supplied to the control board from the auxiliary transformer. It also shows that the 18 VAC is being rectified and should be regulated to +15 VDC. This +15 VDC supply is used to power the circuitry on the control board.

LED2: (Red) This light indicates that the +5.5 VDC is present. This voltage is derived from the +15 VDC supply. The +5.5 VDC supply is used to power the circuitry on the control board.

LED3: (Red) This light indicates that 18 VAC is being supplied to the control board from the auxiliary transformer. It also shows that the 18 VAC is being rectified and should be regulated to -15 VDC. This 15 VDC supply is used to power the circuitry on the control board.

FIGURE F.15 – DISPLAY BOARD TEST POINTS

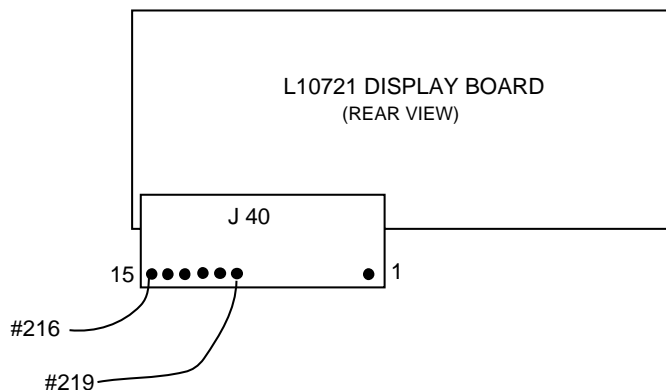

PRO-CUT 55



Return to Section TOC

Return to Section TOC

Return to Section TOC

Return to Section TOC

Return to Master TOC

Return to Master TOC

Return to Master TOC

Return to Master TOC

Return to Section TOC
Return to Master TOC

Return to Section TOC
Return to Master TOC

Return to Section TOC
Return to Master TOC

Return to Section TOC
Return to Master TOC

PRO-CUT 55



TROUBLESHOOTING & REPAIR

CONTROL BOARD REMOVAL AND REPLACEMENT

WARNING

Service and repair should be performed by only Lincoln Electric factory trained personnel. Unauthorized repairs performed on this equipment may result in danger to the technician or machine operator and will invalidate your factory warranty. For your safety and to avoid electrical shock, please observe all safety notes and precautions detailed throughout this manual.

If for any reason you do not understand the test procedures or are unable to perform the test/repairs safely, contact the Lincoln Electric Service Department for electrical troubleshooting assistance before you proceed. Call 1-888-935-3877.

DESCRIPTION

The following procedure will aid the technician in removing the control board for maintenance or replacement.

MATERIALS NEEDED

5/16" Nut driver
Needle-nose pliers

PRO-CUT 55



TROUBLESHOOTING & REPAIR

CONTROL BOARD REMOVAL AND REPLACEMENT (continued)

FIGURE F.16 - CASE FRONT SCREW REMOVAL

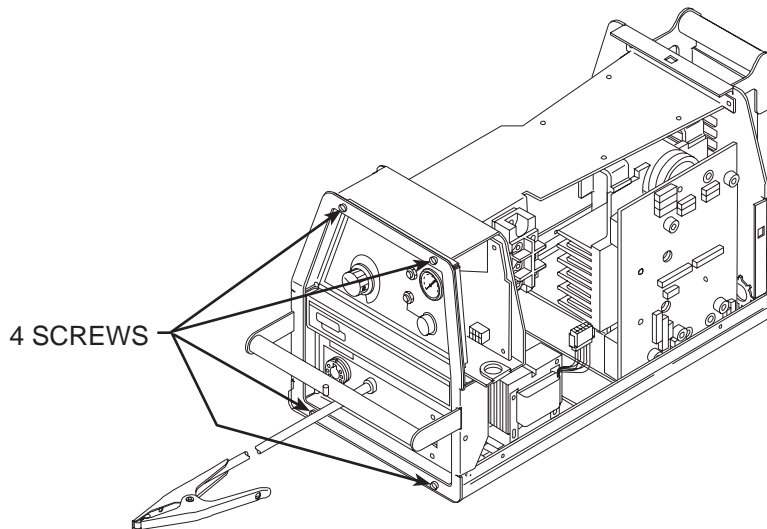

PROCEDURE

1. Remove input power to the Pro-Cut 55 machine.
2. Remove the wraparound cover and perform the **Input Filter Capacitor Discharge Procedure** detailed earlier in this section.
3. Using the 5/16" nut driver, remove the four screws holding the front assembly to the top and base of the machine. See Figure F.16.
4. Carefully slide (do not force) the front away from the rest of the machine about one inch. This will allow more "working" room to remove the control board.

FIGURE F.17 - CONTROL BOARD MOLEX PLUG REMOVAL

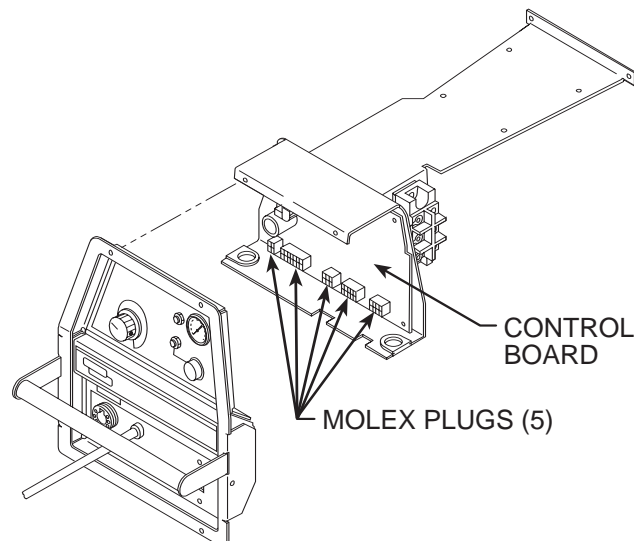

PRO-CUT 55



CONTROL BOARD REMOVAL AND REPLACEMENT (*continued*)

5. Locate the control board and the five molex type plugs connected to it. See **Figure F.17**.
6. Carefully remove the five molex type plugs by depressing the locking tabs and gently extracting the plugs from the P.C. board receptacles.

FIGURE F.18 - CONTROL BOARD REMOVAL FROM MOUNTING PINS

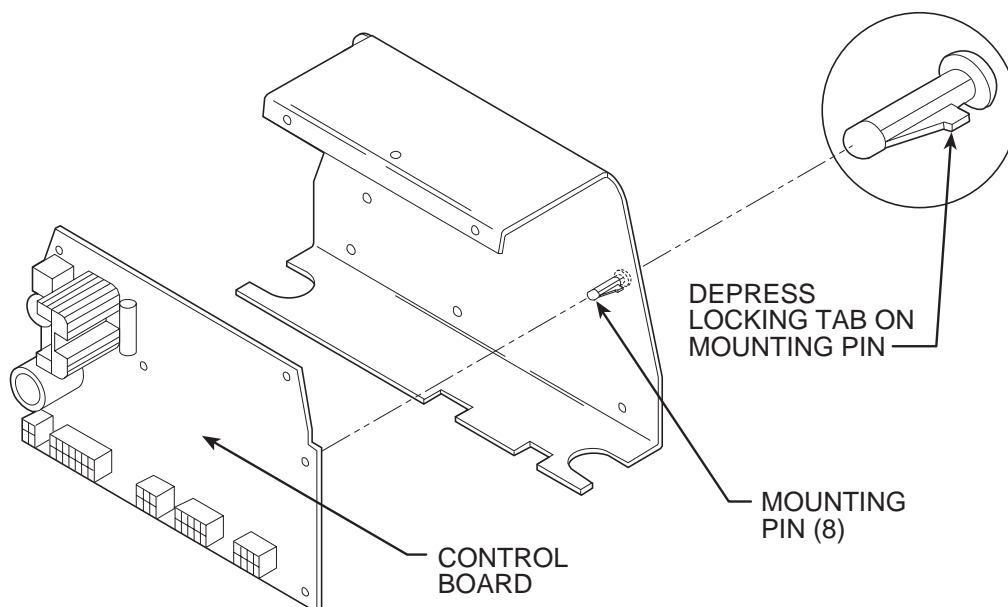

7. Using the needle-nose pliers and screwdriver, gently remove the control board from the eight mounting pins by depressing the tabs on the mounting pins and carefully removing the board from the pins. See Figure F.18.
9. Replace the five molex type plugs in their respective receptacles. Be certain they are securely in place.

⚠ CAUTION

Be sure to follow the recommended static-free methods for handling printed circuit boards. Failure to do so can result in permanent damage to the equipment.

8. When replacing the control board, align the mounting holes with the eight mounting pins and gently slide the P.C. board onto the mounting pins until the board “snaps” onto the pins.

10. Carefully reposition the front assembly in place and install the four mounting screws previously removed.
11. Inspect, clear and secure all leads before installing the case wrap-around reassembly.
12. Using the 5/16” nut driver, install the case wraparound.

Return to Section TOC
Return to Master TOC

Return to Section TOC
Return to Master TOC

Return to Section TOC
Return to Master TOC

Return to Section TOC
Return to Master TOC

PRO-CUT 55



TROUBLESHOOTING & REPAIR

DISPLAY BOARD REMOVAL AND REPLACEMENT

⚠ WARNING

Service and repair should be performed by only Lincoln Electric factory trained personnel. Unauthorized repairs performed on this equipment may result in danger to the technician or machine operator and will invalidate your factory warranty. For your safety and to avoid electrical shock, please observe all safety notes and precautions detailed throughout this manual.

If for any reason you do not understand the test procedures or are unable to perform the test/repairs safely, contact the Lincoln Electric Service Department for electrical troubleshooting assistance before you proceed. Call 1-888-935-3877.

DESCRIPTION

The following procedure will aid the technician in removing the display board for maintenance or replacement.

MATERIALS NEEDED

5/16" Nut driver
Screw driver

PRO-CUT 55



TROUBLESHOOTING & REPAIR

DISPLAY BOARD REMOVAL & REPLACEMENT *(continued)*

FIGURE F.19 - CASE FRONT SCREW REMOVAL

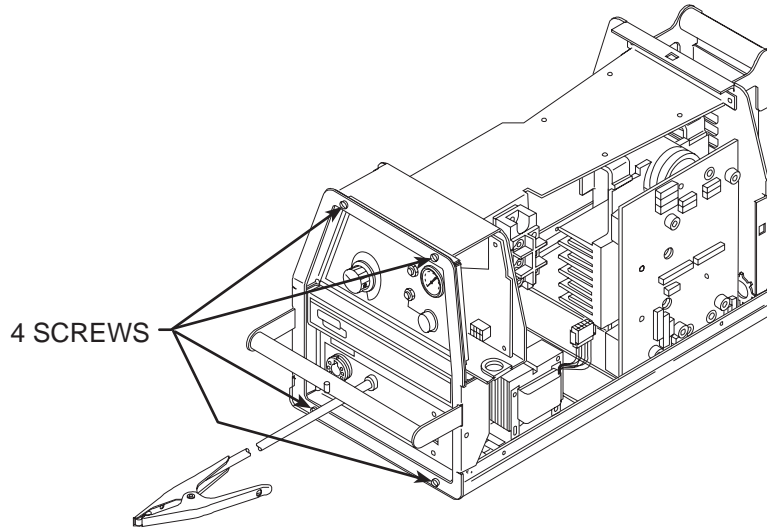

PROCEDURE

1. Remove the input power to the Pro-Cut 55 machine.
2. Remove the wraparound cover and perform the ***Input Filter Capacitor Discharge Procedure*** detailed earlier in this section.
3. Using the 5/16" nut driver, remove the four screws holding the front assembly to the top and base of the machine. See Figure F.19.
4. Carefully slide (do not force) the front away from the rest of the machine about one inch. This will allow more "working" room to remove the display board.

PRO-CUT 55



DISPLAY BOARD REMOVAL & REPLACEMENT *(continued)*

FIGURE F.20 – DISPLAY BOARD REMOVAL

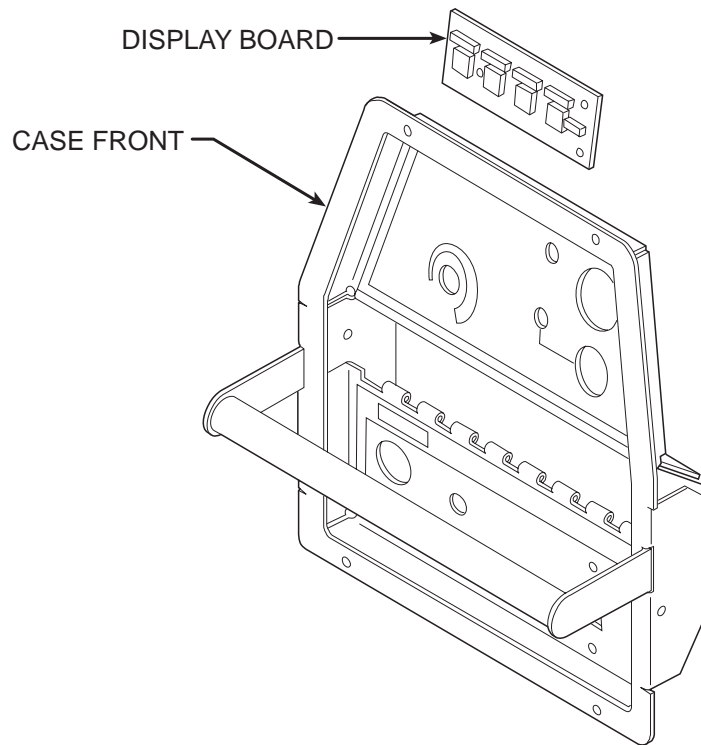

5. Locate the display P.C. board and the one plug connected to it. See Figure F.20.
 6. Gently remove the display P.C. board from the three mounting pins.
- ⚠ CAUTION**
- Be sure to follow the recommended static-free methods for handling printed circuit boards. Failure to do so can result in permanent damage to the equipment.
-
7. Depress the locking tab and remove the plug connector from the display board.
 8. When replacing the display board, carefully connect the plug into the board. Make certain the plug is secure and the locking tab is in place.
 9. Align the display board with the three mounting pins and slide the display board into place.
 10. Carefully reposition the front assembly in place and install the four mounting screws previously removed.
 11. Inspect, clear and secure all leads in preparation for the case wraparound reassembly.
 12. Using the 5/16" nut driver, install the case wraparound.

NOTES

Return to Section TOC
Return to Master TOC

Return to Section TOC
Return to Master TOC

Return to Section TOC
Return to Master TOC

Return to Section TOC
Return to Master TOC

PRO-CUT 55



TROUBLESHOOTING & REPAIR

OUTPUT POWER BOARD REMOVAL AND REPLACEMENT

WARNING

Service and repair should be performed by only Lincoln Electric factory trained personnel. Unauthorized repairs performed on this equipment may result in danger to the technician or machine operator and will invalidate your factory warranty. For your safety and to avoid electrical shock, please observe all safety notes and precautions detailed throughout this manual.

If for any reason you do not understand the test procedures or are unable to perform the test/repairs safely, contact the Lincoln Electric Service Department for electrical troubleshooting assistance before you proceed. Call 1-888-935-3877.

DESCRIPTION

The following procedure will aid the technician in removing the output power board for maintenance or replacement.

MATERIALS NEEDED

- 5/16" Nut driver
- 3/16" Allen type wrench
- 7/16" Wrench
- Penetrox A-13 (Lincoln E2529) Electrical Joint Compound
- Phillips head screw driver
- Torque wrench

PRO-CUT 55



TROUBLESHOOTING & REPAIR

OUTPUT POWER BOARD REMOVAL & REPLACEMENT *(continued)*

FIGURE F.21 – OUTPUT POWER BOARD REMOVAL

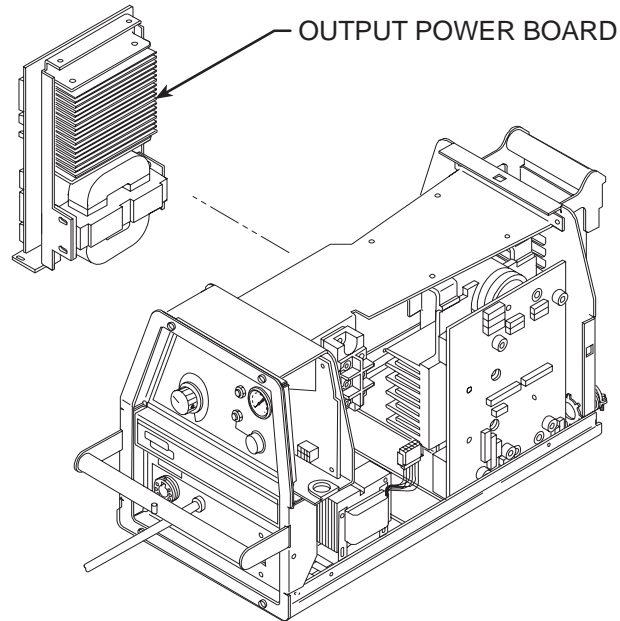

PROCEDURE

1. Remove input power to the Pro-Cut 55 machine.
2. Remove the case wraparound and perform the ***Input Capacitor Filter Discharge Procedure*** detailed earlier in this section.
3. Locate the output power P.C. board and associated lead and plug connections. See Figures F.21 and **F.22**.

PRO-CUT 55



TROUBLESHOOTING & REPAIR

OUTPUT POWER BOARD REMOVAL & REPLACEMENT *(continued)*

FIGURE F.22 – OUTPUT BOARD LEAD LOCATIONS

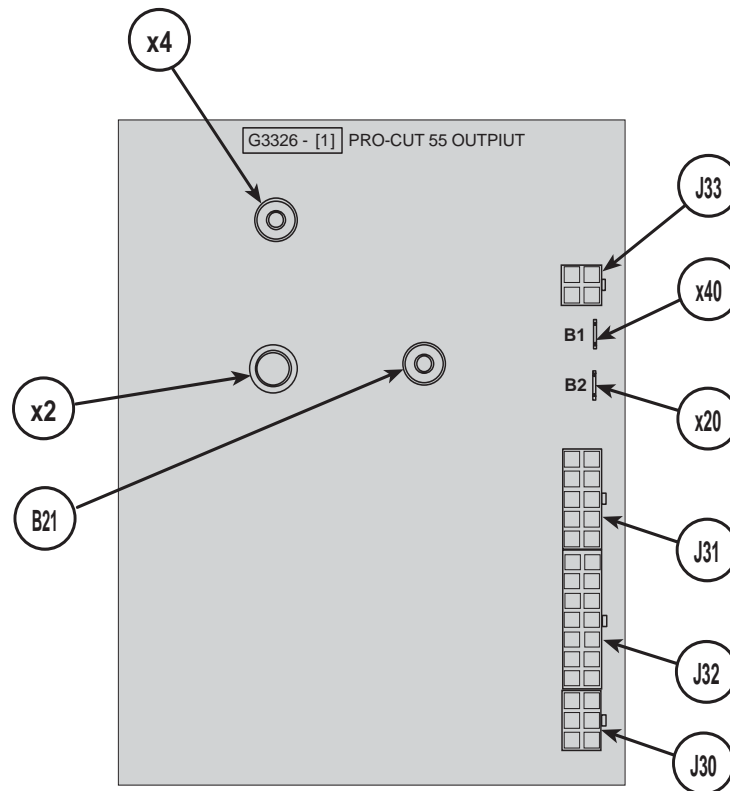

4. Using the 7/16" wrench, remove leads X4, X2 and B21 from the output power board.
5. Remove all plugs from the output power board.
6. Remove leads X20 and X40 from the output power board.
7. Using the phillips head screw driver, remove the two screws from the lower left and right corners of the output power board.
8. Using the 3/16" allen head wrench, remove the four socket screws mounting the output power board to the heat sink.
9. Carefully remove the output power board from the heat sink.

CAUTION

Be sure to follow the recommended static-free methods for handling printed circuit boards. Failure to do so can result in permanent damage to the equipment.

PRO-CUT 55

LINCOLN[®]
ELECTRIC

TROUBLESHOOTING & REPAIR

OUTPUT POWER BOARD REMOVAL & REPLACEMENT *(continued)*

REPLACEMENT PROCEDURE

1. Apply a thin coating of Penetrox A-13 Electrical Joint Compound to the mating surfaces of the output power board and the heat sink. Make sure the surfaces are clean. Do not allow the compound to get into the threaded holes or on the screw threads.

CAUTION

Be sure to follow the recommended static-free methods for handling printed circuit boards. Failure to do so can result in permanent damage to the equipment.

2. Mount the output power board to the heat sink and pre-torque the four socket head screws to 25 inch-pounds.
3. Finish tightening the four screws to 40-48 inch-pounds.
4. Replace the two phillips head screws previously removed.
5. Replace leads X20 and X40.
6. Replace all plugs previously removed.
7. Replace leads X4 and X2.
8. Replace lead B21 and torque it to 70 inch-pounds.
9. Clear and secure all leads and replace the wraparound cover.

TROUBLESHOOTING & REPAIR

PRIMARY POWER BOARD AND FILTER CAPACITOR REMOVAL AND REPLACEMENT

WARNING

Service and repair should be performed by only Lincoln Electric factory trained personnel. Unauthorized repairs performed on this equipment may result in danger to the technician or machine operator and will invalidate your factory warranty. For your safety and to avoid electrical shock, please observe all safety notes and precautions detailed throughout this manual.

If for any reason you do not understand the test procedures or are unable to perform the test/repairs safely, contact the Lincoln Electric Service Department for electrical troubleshooting assistance before you proceed. Call 1-888-935-3877.

DESCRIPTION

The following procedure will aid the technician in removing the primary power board and filter capacitors for maintenance or replacement.

MATERIALS NEEDED

- 5/16" Nut driver
- 3/16" Allen type wrench
- 7/16" Wrench
- Slot-Head screw driver
- Torque wrench
- 3/8" Wrench
- Penetrox A-13 (Lincoln E2529) Electrical Joint Compound

PRO-CUT 55



TROUBLESHOOTING & REPAIR

PRIMARY POWER BOARD AND FILTER CAPACITOR REMOVAL AND REPLACEMENT *(continued)*

FIGURE F.23 – PRIMARY POWER BOARD REMOVAL

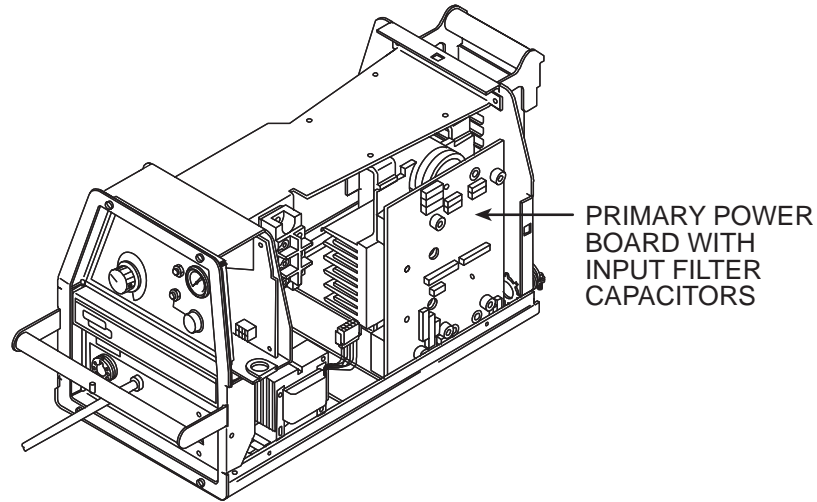

REMOVAL PROCEDURE

1. Remove input power from the Pro-Cut 55 machine.
2. Remove the case wraparound and perform the ***Input Filter Capacitor Discharge Procedure*** detailed earlier in this section.
3. Locate the primary power board and associated lead and plug connections. See Figure F.23.
4. Label the leads for reassembly.
5. Remove Plug J10.
6. Using the 7/16" wrench, remove leads 201, 202A, 203A, 204, 205, 206, 207A, 208 and 209.

PRO-CUT 55



TROUBLESHOOTING & REPAIR

PRIMARY POWER BOARD AND FILTER CAPACITOR REMOVAL AND REPLACEMENT *(continued)*

FIGURE F.24 – POWER BOARD HEATSINK AND CAPACITOR REMOVAL

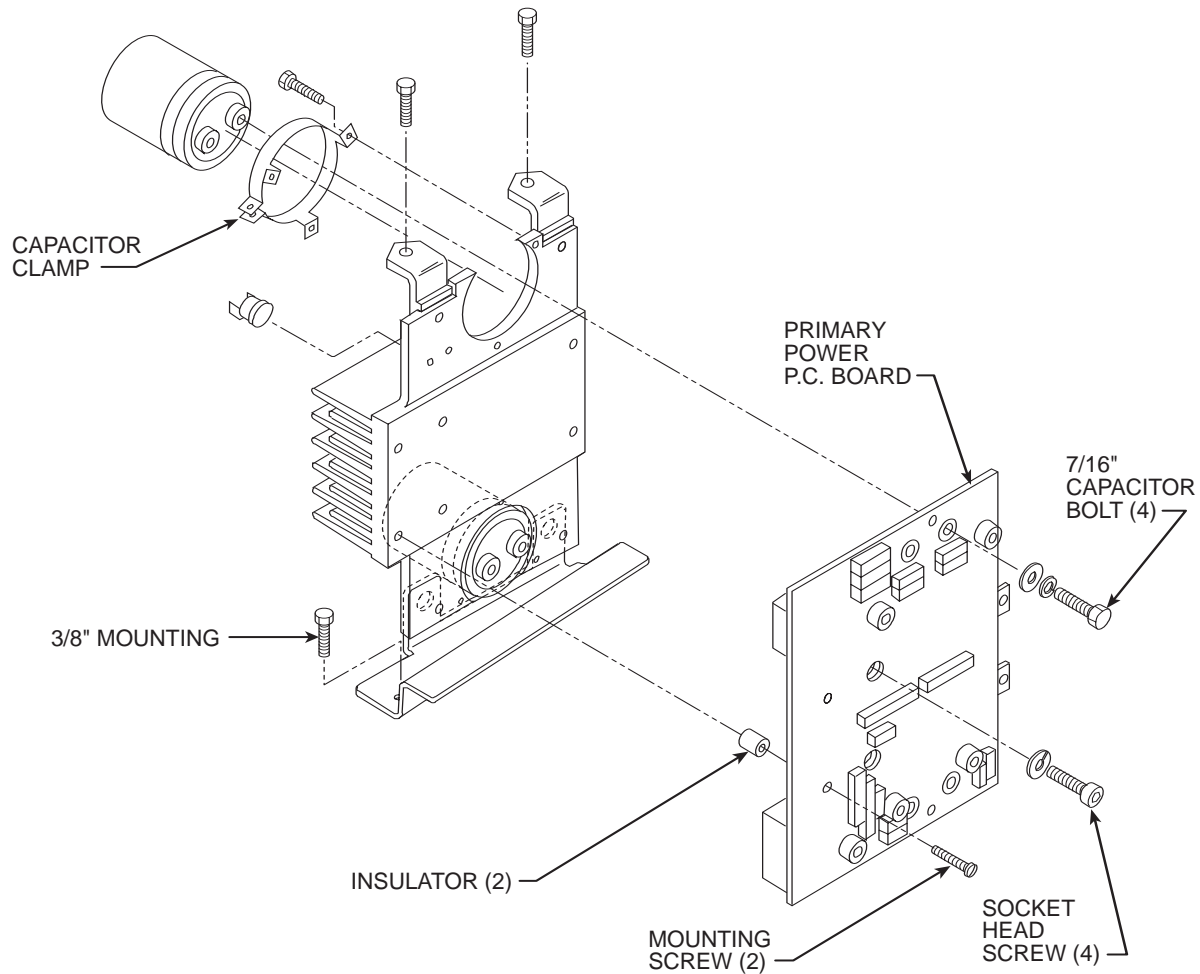

- Using the slot-head screw driver, remove the two mounting screws from the left side of the primary power board. See Figure F.24. Take note of insulator placement for reassembly.
- Using the 3/16" allen type wrench, remove the four socket head screws and lock washers mounting the primary power board to the heat sink.

- Carefully remove the primary power board from the heat sink.

⚠ CAUTION

Be sure to follow the recommended static-free methods for handling printed circuit boards. Failure to do so can result in permanent damage to the equipment.

TROUBLESHOOTING & REPAIR

PRIMARY POWER BOARD AND FILTER CAPACITOR REMOVAL AND REPLACEMENT *(continued)*

CAPACITOR REMOVAL

- Using the 3/8" wrench, remove the four screws holding the heat sink assembly to the upper and bottom sections of the machine. See **Figure F.24**.
- Remove the gas hose restraints from the bottom of the heat sink assembly.
- Remove the two thermostat leads from the thermostat, which is located next to the upper capacitor.
- Carefully remove the heat sink and capacitor assembly. Clear any necessary leads.
- Remove the faulty capacitors by using the slot head screw driver to loosen the clamps. Take note of capacitor position in the clamp. **Observe polarity markings and terminal position.**
- Assemble the four socket head screws and pre-torque them to 25 inch-pounds.
- Make certain the capacitors are lined up correctly so that when the capacitor bolts are assembled through the P.C. board, there will NOT be any distortion to the P.C. board.
- Finish tightening the four screws to 40-48 inch-pounds.
- Assemble the two slot head screws with their appropriate insulators.
- Tighten the capacitor clamps.
- Place the assembly into the machine and connect the two thermostat leads previously removed.
- Secure the assembly to the upper and bottom sections of the unit using the 3/8" wrench and the four screws previously removed.

CAPACITOR REPLACEMENT AND P.C. BOARD REPLACEMENT

- Replace the capacitors by positioning them in the clamps. Do not tighten the clamps. They must be loose when the P.C. board is assembled to the capacitors.
- Apply a thin coating of Penetrox A-13 Electrical Joint Compound to the mating surfaces of the P.C. board and the heat sink and capacitor terminals.
- Mount the P.C. board to the heat sink and capacitor assembly. Make sure the capacitor terminals line up with the holes in the P.C. board and with the correct capacitor polarities.
- Connect the J10 plug.
- Connect leads 201, 204, 205, 208 and 209 previously removed.
- Connect leads 202A, 207A, 206, and 203A to the capacitor terminals. Torque to 50-60 inch-pounds.
- Replace the gas hose restraints previously removed.
- Clear and reposition any leads that may be disturbed.
- Replace the case wraparound cover.

TROUBLESHOOTING & REPAIR

INPUT RECTIFIER BRIDGE REMOVAL AND REPLACEMENT

WARNING

Service and repair should be performed by only Lincoln Electric factory trained personnel. Unauthorized repairs performed on this equipment may result in danger to the technician or machine operator and will invalidate your factory warranty. For your safety and to avoid electrical shock, please observe all safety notes and precautions detailed throughout this manual.

If for any reason you do not understand the test procedures or are unable to perform the test/repairs safely, contact the Lincoln Electric Service Department for electrical troubleshooting assistance before you proceed. Call 1-888-935-3877.

DESCRIPTION

The following procedure will aid the technician in removing the input rectifier bridge for maintenance or replacement.

MATERIALS NEEDED

- 3/16" Allen type wrench
- Phillips head screw driver
- Torque wrench
- Penetrox A13 (Lincoln E2529) Electrical Joint Compound
- Essex DC-4-8 (Lincoln E3539) Electrical Insulating Compound

PRO-CUT 55



TROUBLESHOOTING & REPAIR

INPUT RECTIFIER BRIDGE REMOVAL AND REPLACEMENT *(continued)*

PROCEDURE

1. Remove input power to the Pro-Cut 55.
2. Perform the ***Input Filter Capacitor Discharge Procedure*** detailed earlier in this section.
3. Locate the input rectifier and the leads connected to it. See Figure F.25.
4. Identify and mark the leads connected to the rectifier terminals.
5. With the phillips head screw driver, remove the lead terminals connected to the rectifier terminals.
6. Using the 3/16" allen wrench, remove the two cap head screws and washers mounting the input rectifier bridge to the center panel assembly.

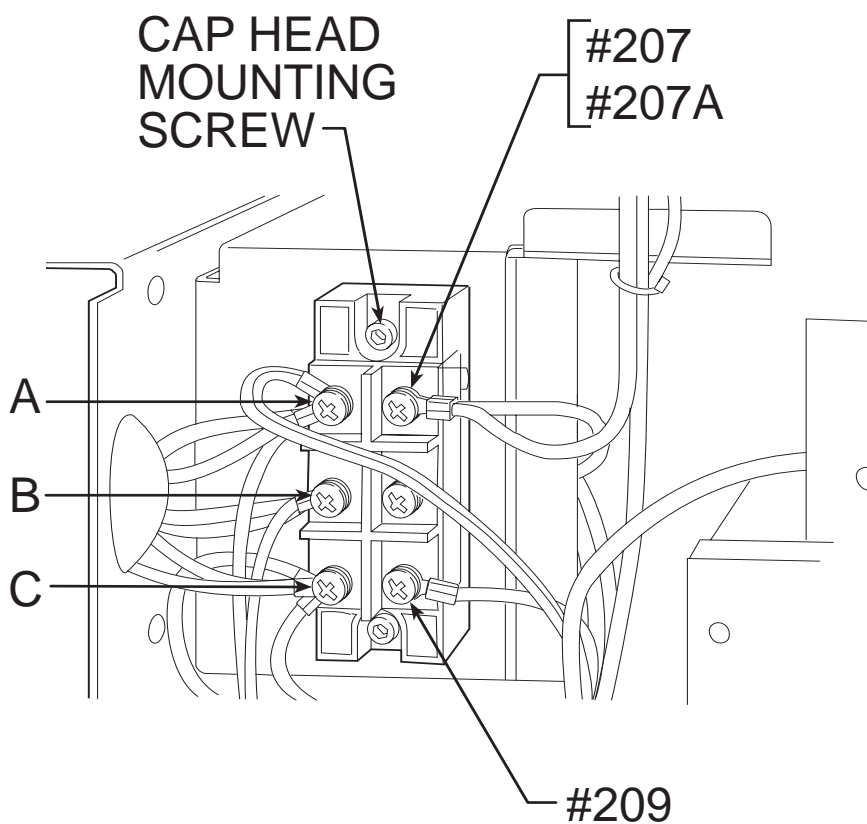

FIGURE F.25 – INPUT RECTIFIER LEAD LOCATIONS

PRO-CUT 55



TROUBLESHOOTING & REPAIR

INPUT RECTIFIER BRIDGE REMOVAL AND REPLACEMENT *(continued)*

7. Carefully remove the input rectifier bridge.
8. When installing a new input rectifier apply a thin coating of Penetrox A-13 Heat Sink Compound (Lincoln E2529) to the mating surfaces. Torque the mounting cap screws and nuts to 44 in-lbs.
9. Reconnect the 10 leads to the correct terminals and torque the phillips head screws to 31 in-lbs.
10. Apply Essex DC-4-8 Insulating Compound to all six screw heads and terminals. The heavy input lead terminals should be against the rectifier terminals.

Return to Section TOC

Return to Section TOC

Return to Section TOC

Return to Section TOC

Return to Master TOC

Return to Master TOC

Return to Master TOC

Return to Master TOC

PRO-CUT 55



TROUBLESHOOTING & REPAIR

RETEST AFTER REPAIR

Should a machine under test be rejected for any reason requiring the removal of any mechanical part that could affect the machine's electrical characteristics, or if any electrical components are repaired or replaced, the machine must be retested.

INPUT IDLE AMPS AND WATTS

Input Volts/Hertz	Idle Amps	Idle Watts
230/60	0.42	98

Output Current Range	25 - 55 Amps
----------------------	--------------

Maximum Open Circuit Voltage	335 Volts
------------------------------	-----------

PRO-CUT 55



Return to Section TOC
 Return to Master TOC
 Return to Section TOC
 Return to Master TOC
 Return to Section TOC
 Return to Master TOC
 Return to Section TOC
 Return to Master TOC

NOTES

Return to Section TOC Return to Section TOC Return to Section TOC
Return to Master TOC Return to Master TOC Return to Master TOC

PRO-CUT 55



TABLE OF CONTENTS
ELECTRICAL DIAGRAMS SECTION

Electrical Diagrams Section	Section G
Wiring Diagram (208V, 230V, 460V) (L10634)	G-2
Plasma Output Board Schematic (L10722)	G-3
Power P.C. Board Schematic (L10616)	G-4
Display P.C. Board Assembly (L10721-1)	G-5
Display Board (M18920)	G-6
Control Schematic (G3327)	G-7
Control P.C. Board Assembly (G3328-1)	G-8
Control P.C. Board Assembly (G3328-2)	G-9
Output P.C. Board Assembly (G3326-1)	G-10
Output P.C. Board Assembly (G3326-2)	G-11
Power P.C. Board Assembly (G3172-1)	G-12
Power P.C. Board Assembly (G3172-2)	G-13

Return to Master TOC

Return to Master TOC

Return to Master TOC

Return to Master TOC

WIRING DIAGRAM PRO-CUT 55

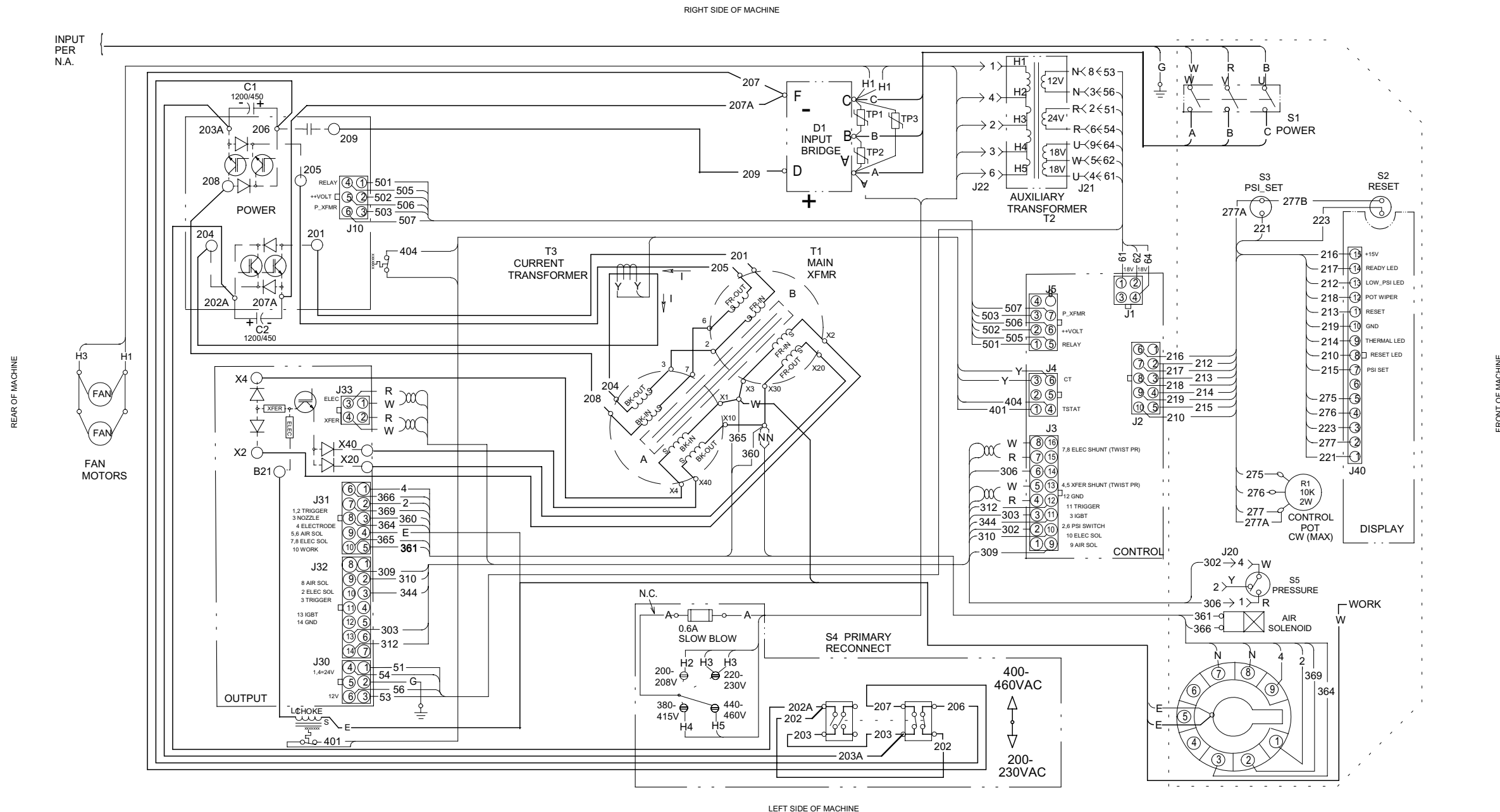

- NOTES:
- N.A.
 - 1. FOR MACHINES SUPPLIED WITH INPUT CABLE
FOR SINGLE PHASE INPUT: CONNECT GREEN LEAD TO GROUND PER NATIONAL ELECTRIC CODE. CONNECT BLACK & WHITE LEADS TO SUPPLY CIRCUIT. WRAP RED LEAD WITH TAPE TO PROVIDE 600V. INSULATION.
FOR THREE PHASE INPUT: CONNECT GREEN LEAD TO GROUND PER NATIONAL ELECTRIC CODE. CONNECT BLACK, RED & WHITE LEADS TO SUPPLY CIRCUIT.
 - 2. FOR MACHINES NOT SUPPLIED WITH INPUT CABLE
FOR SINGLE PHASE INPUT: GROUND MACHINE PER NATIONAL AND LOCAL ELECTRICAL CODES. CONNECT TERMINALS U & W TO SUPPLY CIRCUIT.
FOR THREE PHASE INPUT: GROUND MACHINE PER NATIONAL AND LOCAL ELECTRICAL CODES. CONNECT TERMINALS U, V & W TO SUPPLY CIRCUIT.
 - N.B. SINCE COMPONENTS OR CIRCUITRY OF A PRINTED CIRCUIT BOARD MAY CHANGE WITHOUT AFFECTING THE INTERCHANGEABILITY OF A COMPLETE BOARD, THIS DIAGRAM MAY NOT SHOW THE EXACT COMPONENTS OR CIRCUITRY HAVING A COMMON CODE NUMBER.
 - N.C. PLACE "A" LEAD ON APPROPRIATE CONNECTION FOR INPUT VOLTAGE. CONNECTION SHOWN IS FOR 440-460V OPERATION.

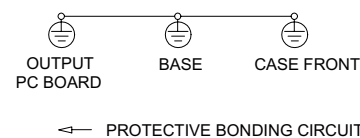

COLOR CODE:
B = BLACK
G = GREEN
R = RED
W = WHITE
U = BLUE
N = BROWN
Y = YELLOW

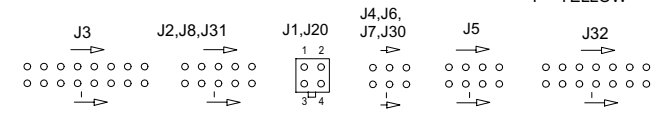

ELECTRICAL SYMBOLS PER E1537
CONNECTOR CAVITY NUMBERING SEQUENCE (VIEWED FROM COMPONENT SIDE OF BOARD)
L10634 8-7-98A

NOTE: This diagram is for reference only. It may not be accurate for all machines covered by this manual. The wiring diagram specific to your code is pasted inside one of the enclosure panels of your machine.

Return to Section TOC

SCHEMATIC-POWER PC BOARD

Return to Section TOC
Return to Master TOC

Return to Section TOC
Return to Master TOC

Return to Section TOC
Return to Master TOC

Return to Section TOC
Return to Master TOC

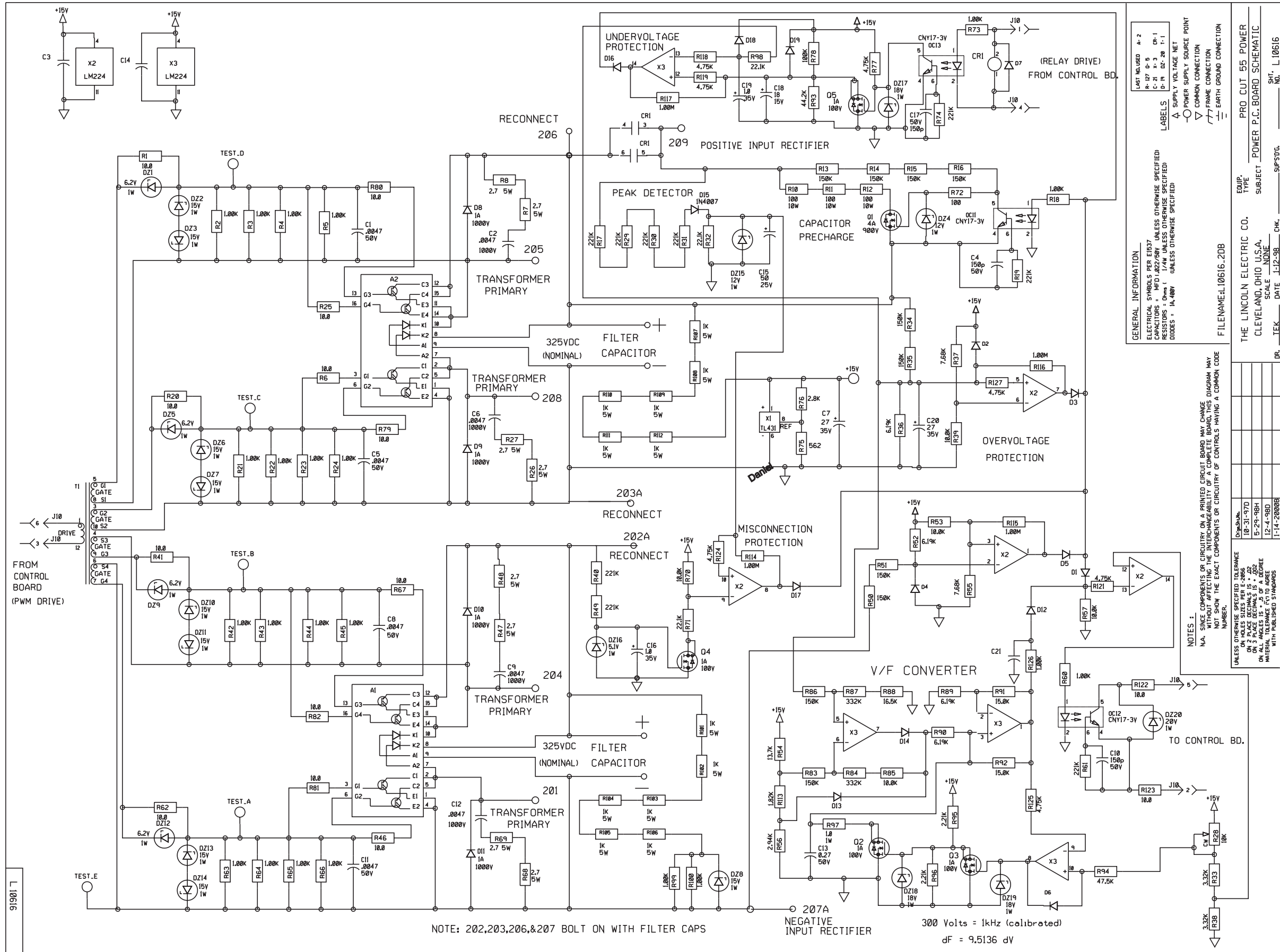

GENERAL INFORMATION
 ELECTRICAL SYMBOLS PER E157
 CAPACITORS - UNLESS OTHERWISE SPECIFIED
 RESISTORS - UNLESS OTHERWISE SPECIFIED
 DIODES - IA,400V UNLESS OTHERWISE SPECIFIED

LABELS
 ▲ SUPPLY VOLTAGE NET
 ○ POWER SUPPLY SOURCE POINT
 ○ COMMON CONNECTION
 ▽ FRAME CONNECTION
 ⊥ EARTH GROUND CONNECTION

FILENAME: L10616_2.D8

NOTES:
 1. N/A. SINCE COMPONENTS OR CIRCUITRY ON A PRINTED CIRCUIT BOARD MAY CHANGE WITHOUT AFFECTING THE INTERCHANGEABILITY OF A COMPLETE BOARD, THIS DIAGRAM MAY NOT SHOW THE EXACT COMPONENTS OR CIRCUITRY OF CONTROLS HAVING A COMMON CODE NUMBER.
 2. UNLESS OTHERWISE SPECIFIED TOLERANCE ON HOLES SIZES PER E-28956
 ON 3 PLACE DECIMALS IS + .002
 ON 2 PLACE DECIMALS IS + .005
 ON ALL ANGLES IS + .25 OF A DEGREE
 MATERIAL TOLERANCE TO AGREE WITH PUBLISHED STANDARDS

DR. _____ DATE 1-12-98 CHK. _____
 THE LINCOLN ELECTRIC CO.
 CLEVELAND, OHIO U.S.A.
 SCALE NONE
 SUBJECT POWER P.C. BOARD SCHEMATIC
 EQUIP. TYPE _____
 PRO CUT 55 POWER
 SHT. L 10616

NOTE: This diagram is for reference only. It may not be accurate for all machines covered by this manual.

PC BOARD ASSEMBLY-DISPLAY

Return to Section TOC
Return to Master TOC

Return to Section TOC
Return to Master TOC

Return to Section TOC
Return to Master TOC

Return to Section TOC
Return to Master TOC

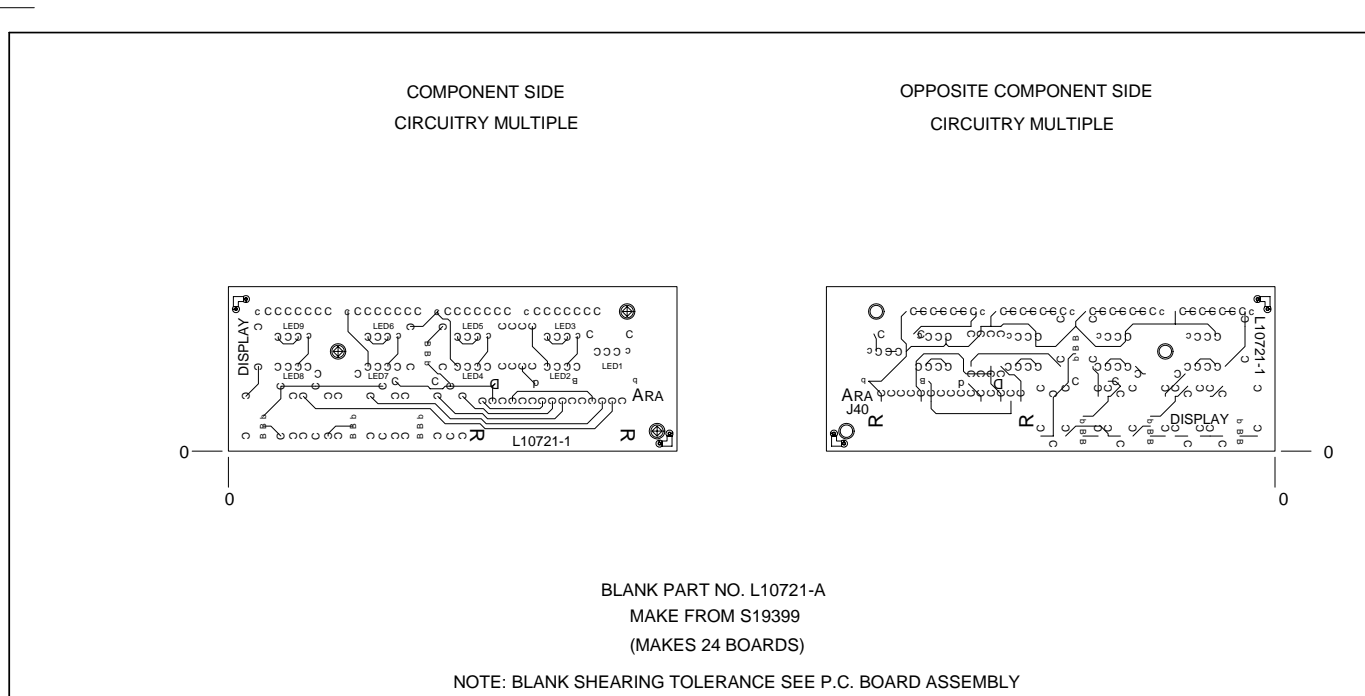

BLANK PART NO. L10721-A
MAKE FROM S19399
(MAKES 24 BOARDS)

NOTE: BLANK SHEARING TOLERANCE SEE P.C. BOARD ASSEMBLY

ITEM	QTY.	PART No.	IDENTIFICATION
C1,C2,C3,C4	4	S16668-4	2700pF/50
C5	1	S13490-25	4.7/35
DZ1	1	T12702-27	1N4740
N.B. LED1	1	M18875-1	LIGHT BAR,LED,YELLOW
N.B. LED2,LED7	2	M18875-5	LIGHT BAR,LED,RED
N.B. LED3,LED6	2	M18875-2	LIGHT BAR,LED,RED
N.B. LED4	1	M18875-6	LIGHT BAR,LED,YELLOW
N.B. LED5	1	M18875-3	LIGHT BAR,LED,YELLOW
N.B. LED8	1	M18875-7	LIGHT BAR,LED,GREEN
N.B. LED9	1	M18875-4	LIGHT BAR,LED,GREEN
Q1,Q2,Q3,Q4	4	T12704-68	2N4401
R1,R5,R9,R13	4	S19400-3321	3.32K 1/4W
R2,R6,R10,R14	4	S19400-6811	6.81K 1/4W
R3,R4,R7,R8,R11,R12	6	S19400-1000	100 1/4W
R15,R16	2	S19400-75R0	75 1/4W
R17	1	S19400-8250	825 1/4W
R18,R19	2	S19400-2671	2.67K 1/4W
R20	1	S19400-2430	243 1/4W

ITEM	REQ'D	PART NO.	IDENTIFICATION
1	1	SEE BLANK	P.C. BOARD BLANK
2	1	S19365-15	RIGHT ANGLE HEADER
3	3 oz	E2861	SEALANT

CAPACITORS = MFD/VOLTS
INDUCTANCE = HENRY'S

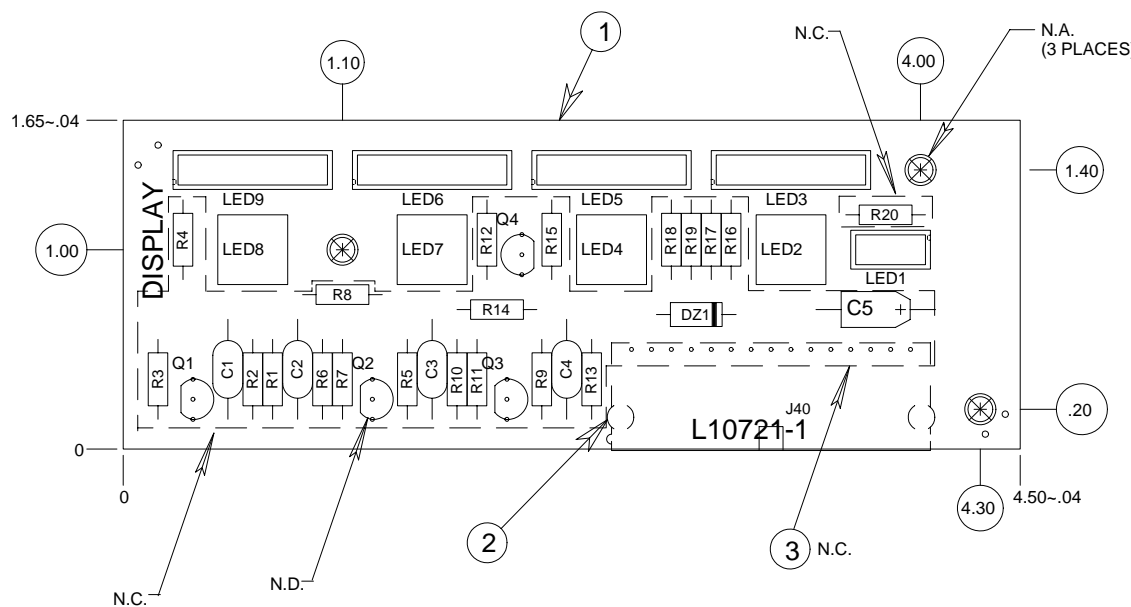

MANUFACTURED AS:
L10721-1A0
IDENTIFICATION CODE

MAKE PER E1911
ENCAPSULATE WITH E1844
TEST PER E3733-D

NOTES:

- N.A. DO NOT COAT.
- N.B. DO NOT COAT VIEWING LENS WITH ENCAPSULATION MATERIAL.
- N.C. COAT WITH ITEM 3 COMPONENT SIDE AFTER ENCAPSULATION.
- N.D. HEIGHT OF RTV AND COMPONENTS NOT TO EXCEED .36".
- N.F. COAT WITH ITEM 3 ALL TRACES AND SOLDER CONNECTIONS ON NON-COMPONENT SIDE OF BOARD PRIOR TO ENCAPSULATION.

THE LINCOLN ELECTRIC CO.
CLEVELAND, OHIO U. S. A.

PRO-CUT 55
DISPLAY P.C. BOARD ASBLY.

DATE: 10/27/87
SCALE: AS SHOWN
SHEET NO. L 10721-1

UNLESS OTHERWISE SPECIFIED TOLERANCE IS:
DIMENSIONS IN PLACE DECIMALS IS ± .02"
DIMENSIONS IN PLACE INCHES IS ± .005"
ON ALL ANGLES DIMENSIONS OF 45 DEGREE
MATERIAL TOLERANCE (") TO AGREE
WITH PUBLISHED STANDARDS.

NOTE: Lincoln Electric assumes no responsibility for liabilities resulting from board level troubleshooting. PC Board repairs will invalidate your factory warranty. Individual Printed Circuit Board Components are not available from Lincoln Electric. This information is provided for reference only. Lincoln Electric discourages board level troubleshooting and repair since it may compromise the quality of the design and may result in danger to the Machine Operator or Technician. Improper PC board repairs could result in damage to the machine.

PC BOARD ASSEMBLY-CONTROL (G3328-1)

Return to Section TOC
Return to Master TOC

Return to Section TOC
Return to Master TOC

Return to Section TOC
Return to Master TOC

Return to Section TOC
Return to Master TOC

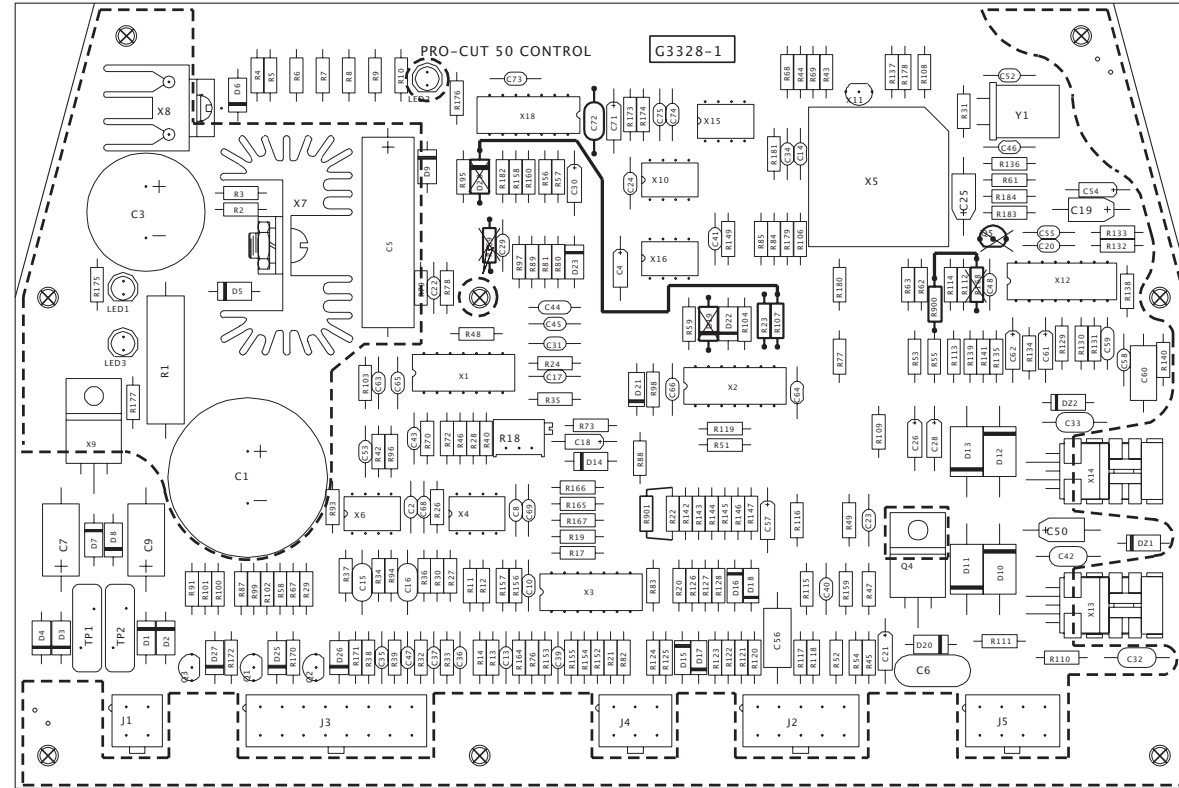

ITEM	REQ'D	PART NO.	DESCRIPTION
C1	1	S13490-92	3300/50
C2,C8,C10,C13,C14,C17,C20	31	S16668-5	022/50
C23,C24,C29,C31,C34,C35			
C36,C37,C39,C40,C41,C47			
C53,C55,C58,C63,C64,C65			
C66,C68,C69,C73,C74,C75			
C3	1	S13490-121	1000/35
C4,C18	2	S13490-63	.47/50
C5	1	S13490-71	100/50
C6	1	T11577-52	.0047 or .005/1400
C7,C9	2	S13490-93	27/35
C15,C16,C32,C33,C42	5	S16668-11	1/50
C19,C25,C50	3	S13490-25	4.7/35
C21,C26,C28,C30,C54,C57	8	S13490-42	1.0/35
C62,C71			
C22,C43,C44	3	S16668-9	150pf/100
C45	1	S16668-4	700pf/50
C48,C52	2	S16668-13	10pf/100
C48	1	S16668-8	330pf/100
C56	1	S13490-108	.15/100
C59	1	S16668-3	100pf/100
C60	1	S13490-126	.018/50V
C61	1	S13490-19	1.8/20
C72	1	S16668-10	4700pf/50
D1,D2,D3,D4,D5,D6,D7,D8,D9	16	T12199-1	1N4004
D14,D20,D22,D23,D25		D26,D27	
D10,D11,D17,D13	4	T12705-37	1N5822 SCHOTTKY BARRIER DIODE
D15,D16,D17,D18,D21	5	T12705-34	1N4936
D21,D22	2	T12702-19	1N4742A
J1	1	S18248-4	HEADER
J2	1	S18248-10	HEADER
J3	1	S18248-16	HEADER
J4	1	S18248-6	HEADER
J5	1	S18248-8	HEADER
LED1,LED2,LED3	3	T13652-2	RED LED
Q1,Q2,Q3	3	T12704-68	2N4401
Q4	1	T12704-80	HEXFET TRANS. (SS)
Q5	1	T12704-69	HEXFET TRANS. (SS)
R1	1	T13165-16	1.0 OHM, 5W RESISTOR
R2,R46,R132	3	S19400-2671	2.67K 1/4W
R3,R30,R32,R33,R34,R36,R37	9	S19400-2430	243 1/4W
R38,R39			
R4	1	S19400-3081	30.1 1/4W
R5	1	S19400-6190	619 1/4W
R6	1	S19400-8251	8.25K 1/4W
R7	1	S19400-3921	3.92K 1/4W
R8	1	S19400-2001	2.0K 1/4W
R9,R88,R103	4	S19400-1001	1K 1/4W
R10,R42,R95,R96	4	S19400-5110	511 1/4W
R11,R12,R13,R14	4	S19400-3320	332 1/4W
R17,R26,R27,R49,R51,R59	35	S19400-1002	10K 1/4W
R61,R62,R63,R68,R69,R81			
R84,R93,R94,R104,R106,R108			
R134,R138,R139,R152			
R153,R154,R156,R158,R160			
R164,R165,R166,R178			
R179,R180,R181,R182			
R18	1	S24073-1	10K, 1/2W TRIMMER
R19,R47,R53,R55,R57,R85	8	S19400-5111	5.11K 1/4W
R149,R157			
R20,R22,R110,R111,R124,R125	16	S19400-1080	10 1/4W
R126,R127,R128,R142,R143			
R144,R145,R146,R147,R901			
R21,R23	2	S19400-1822	18.2K 1/4W
R24,R35	2	S19400-2210	221 1/4W
R28,R112,R115,R116,R117	7	S19400-3321	3.32K 1/4W
R118,R119			
R29,R91,R102	3	S19400-8250	825 1/4W
R31	1	S19400-1004	10K 1/4W
R40,R73,R107	3	S19400-7681	7.68K 1/4W
R43,R44,R45,R136,R137,R170	8	S19400-4751	4.75K
R171,R172			
R48,R67,R70,R87,R101	5	S19400-4752	47.5K 1/4W
R52,R54,R56	3	S19400-1000	100 1/4W
R58,R76,R99,R100	4	S19400-3741	3.74K 1/4W
R72,R900	2	S19400-1501	1.5K 1/4W
R77	1	S19400-2211	2.21K 1/4W
R82,R175,R177	3	S19400-1301	1.3K 1/4W
R78,R113,R114,R159	4	S19400-1211	1.21K 1/4W
R79,R83,R155,R167	4	S19400-2213	221K 1/4W
R80,R89	2	S19400-1003	100K 1/4W
R98	1	S19400-2431	2.43K 1/4W
R97	1	S19400-8252	82.5K 1/4W
R109	1	S19400-6811	6.81K 1/4W
R120,R121,R122,R123	4	S19400-2687	26.7 1/4W
R130	1	S19400-2212	22.1K 1/4W
R131,R174	2	S19400-6812	68.1K 1/4W
R133,R173	2	S19400-2672	26.7K 1/4W
R140,R141	2	S19400-2670	267 1/4W
R135,R183	2	S19400-1502	15K 1/4W
R176	1	S19400-4750	475 1/4W
R129,R184	2	S19400-5621	5.62K 1/4W
TP1,TP2	2	T13640-15	15J
X1,X2	2	S15128-16	LINEAR INTEGRATED CIRCUIT
X3	1	S15128-4	LM224 OP-AMP
X4,X6	2	S15128-13	PRECISION OP AMP IC
X5	1	S24085-1	DM ASSEMBLY
X7	1	S18647	REGULATOR ASBLY
X8	1	S18395-13	SV REG. ASBLY
X9	1	S15128-12	VOLTAGE REGULATOR
X10,X16	2	S15018-18	IC ARRAY, CLAMPING
X11	1	M15102-3	RESET I.C. UNDERVOLT. SENSING CIR. (SS)
X12	1	M15458-2	PWM CONTROLLER I.C. (SS)
X13,X14	2	S15018-19	IC, DRIVER, FET, 6A
X15	1	M15105-8	CMOS CONVERTER,D/A,SERIAL,10-BIT (SS)
X18	1	M13552-2	FREQ. TO VOLTAGE CONVERTER
Y1	1	S16665-5	8.0 MHZ

NOTE: Lincoln Electric assumes no responsibility for liabilities resulting from board level troubleshooting. PC Board repairs will invalidate your factory warranty. **Individual Printed Circuit Board Components are not available from Lincoln Electric.** This information is provided for reference only. Lincoln Electric discourages board level troubleshooting and repair since it may compromise the quality of the design and may result in danger to the Machine Operator or Technician. Improper PC board repairs could result in damage to the machine.



PC BOARD ASSEMBLY-CONTROL (G3328-2)

Return to Section TOC
Return to Master TOC

Return to Section TOC
Return to Master TOC

Return to Section TOC
Return to Master TOC

Return to Section TOC
Return to Master TOC

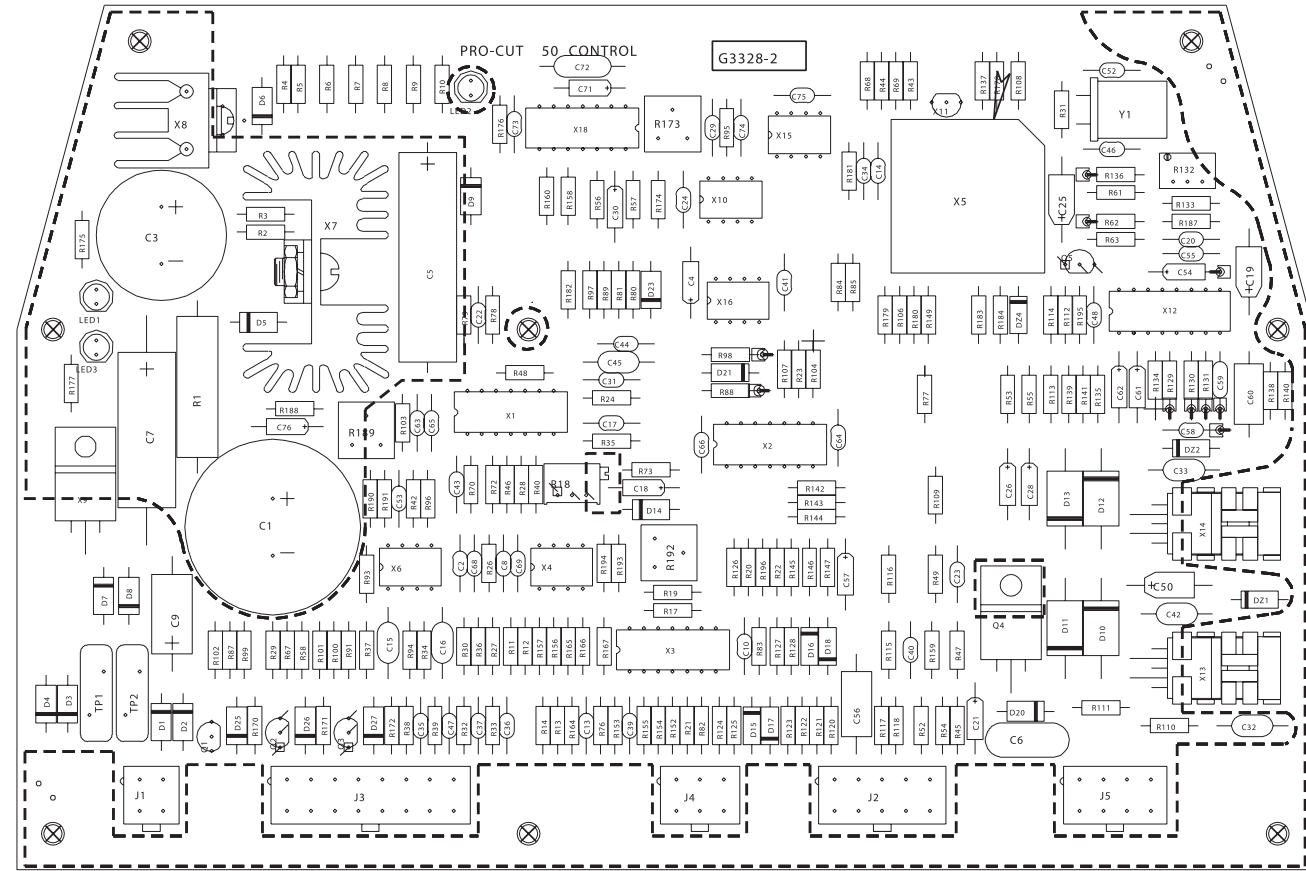

ITEM	REQ'D	PART NO.	DESCRIPTION
C1	1	S13490-92	3300/50
C2, C8, C10, C13, C14, C17, C20	31	S16668-5	.022/50
C23, C24, C29, C31, C34, C35			
C36, C37, C39, C40, C41, C47			
C53, C55, C58, C63, C64, C65			
C66, C68, C69, C73, C74, C75			
C3	1	S13490-121	1000/35
C4, C18	2	S13490-63	.47/50
C5	1	S13490-71	100/50
C6	1	T11577-52	.0047 or .005/1400
C7	1	S13490-72	50/50
C9	1	S13490-93	27/35
C15, C16, C32, C33, C42	5	S16668-11	.1/50
C19, C25, C50	3	S13490-25	4.7/35
C21, C26, C28, C30, C54, C57	8	S13490-42	1.0/35
C62, C71			
C22, C43, C44	3	S16668-9	150pF/100
C45	1	S16668-4	2700pF/50
C46, C52	2	S16668-13	10pF/100
C48	1	S16668-8	330pF/100
C56	1	S13490-108	.15/100
C59	1	S16668-3	100pF/100
C60	1	S13490-126	.018/50V
C61	1	S13490-19	1.8/20
C72	1	S16668-10	4700pF/50
C76	1	S13490-135	1.0/50V
D1, D2, D3, D4, D5, D6, D7, D8, D9	15	T12199-1	1N4004
D14, D20, D23, D25, D26, D27			
D10, D11, D12, D13	4	T12705-37	1N5822 SCHOTTKY BARRIER DIODE
D15, D16, D17, D18	4	T12705-34	1N4936
D21	1	T12705-23	1N5818
D21, D22	2	T12702-19	1N4742A
D24	1	T12702-52	1N4733A
J1	1	S18248-4	HEADER
J2	1	S18248-10	HEADER
J3	1	S18248-16	HEADER
J4	1	S18248-6	HEADER
J5	1	S18248-8	HEADER
LED1, LED2, LED3	3	T13657-2	RED LED
Q1, Q2, Q3	3	T12704-68	2N4401
Q4	1	T12704-80	HEXFET TRANS. (SS)
Q5	1	T12704-69	2N4403
R1	1	T13165-16	1.0 OHM, 5W RESISTOR
R2, R46, R133	3	S19400-2671	2.67K 1/4W
R3, R30, R32, R33, R34, R36, R37	9	S19400-2430	243 1/4W
R38, R39			
R4	1	S19400-30R1	30.1 1/4W
R5	1	S19400-6190	619 1/4W
R6	1	S19400-8251	8.25K 1/4W
R7, R190, R191, R193, R194	5	S19400-3921	3.92K 1/4W
R8	1	S19400-2001	2.0K 1/4W
R9, R88, R103	3	S19400-1001	1K 1/4W
R10, R42, R95, R96	4	S19400-5110	511 1/4W
R11, R12, R13, R14	4	S19400-3320	332 1/4W
R17, R26, R27, R61, R62, R63	32	S19400-1002	10K 1/4W
R68, R69, R81, R84, R93, R94			
R104, R106, R108, R134, R138			
R139, R152, R153, R154, R156			
R158, R160, R164, R165, R166			
R178, R179, R180, R181, R182			
R18	1	S24073-1	10K, 1/2W, TRIMMER
R19, R63, R66, R67, R86, R149	7	S19400-5111	5.11K 1/4W
R157			
R20, R22, R110, R111, R124	16	S19400-10R0	10 1/4W
R125, R126, R127, R128, R142			
R143, R144, R145, R146, R147			
R196			
R21, R23	2	S19400-1822	18.2K 1/4W
R24, R35	2	S19400-2210	221 1/4W
R28, R112, R115, R116, R117	6	S19400-3321	3.32K 1/4W
R118			
R29, R91, R102	3	S19400-8250	825 1/4W
R31	1	S19400-1004	1M 1/4W
R40, R73, R107	3	S19400-7681	7.68K 1/4W
R43, R44, R45, R136, R137, R170	8	S19400-4751	4.75K
R171, R172			
R47, R49, R80, R89, R183	5	S19400-1003	100K 1/4W
R48, R67, R70, R87, R101	5	S19400-4752	47.5K 1/4W
R52, R54, R56	3	S19400-1000	100 1/4W
R58, R76, R99, R100	4	S19400-3741	3.74K 1/4W
R72, R187, R195	3	S19400-1501	1.5K 1/4W
R77, R82, R175, R177	4	S19400-1301	1.3K 1/4W
R78, R113, R114, R159	4	S19400-1211	1.21K 1/4W
R79, R83, R155, R167	4	S19400-2213	221K 1/4W
R97	1	S19400-8252	82.5K 1/4W
R98	1	S19400-2431	2.43K 1/4W
R109	1	S19400-6811	6.81K 1/4W
R120, R121, R122, R123	4	S19400-26R7	26.7 1/4W
R129	1	S19400-6621	6.62K 1/4W
R130	1	S19400-2212	22.1K 1/4W
R131	1	S19400-6812	68.1K 1/4W
R132	1	S16296-5	10K TRIMMER
R135, R184	2	S19400-1502	15K 1/4W
R140, R141	2	S19400-2670	267 1/4W
R173	1	T10812-39	50K 1/2W TRIMMER
R174	1	S19400-5622	56.2 1/4W
R176	1	S19400-4750	475 1/4W
R188	1	S19400-3922	39.2K 1/4W
R189, R192	2	T10812-68	1K 1/2W TRIMMER
TP1, TP2	2	T13640-15	15J
X1	1	S15128-16	IC, LT1014, LINEAR INTEGRATED CIRCUIT
X2	1	S15128-18	IC, 33074A, OP-AMP, GUARD, HIGH-PERF
X3	1	S15128-4	IC, LM224, OP-AMP
X4, X6	2	S15128-13	IC, OP27GZ, PRECISION OP-AMP
X5	1	S24085-3	ROM ASBLY (SS)
X7	1	S18647	IC, LM350, VOLT REG WITH H/S ASSEMBLY
X8	1	S18395-13	IC, 7805, 5V VOLTAGE REGULATOR ASBLY
X9	1	S15128-12	IC, 7905, VOLTAGE REGULATOR
X10, X16	2	S15018-18	IC, TCF6000, ARRAY, CLAMPING, HEX
X11	1	M15102-3	IC, S8054HN, CMOS, UNDERVOLT-SENSING (SS)
X12	1	M15458-2	IC, 3846, PWM CONTROLLER (SS)
X13, X14	2	S15018-19	IC, DRIVER, FET, 6A
X15	1	M15105-8	IC, AD739, CMOS, CONV, D/A, SERIAL, 10BI (SS)
X18	1	M13552-2	IC, LM2907, CONVERTER, F/V
Y1	1	S16665-5	B, 0 MHz

NOTE: Lincoln Electric assumes no responsibility for liabilities resulting from board level troubleshooting. PC Board repairs will invalidate your factory warranty. **Individual Printed Circuit Board Components are not available from Lincoln Electric.** This information is provided for reference only. Lincoln Electric discourages board level troubleshooting and repair since it may compromise the quality of the design and may result in danger to the Machine Operator or Technician. Improper PC board repairs could result in damage to the machine.



PC BOARD ASSEMBLY-POWER (G3172-1)

Return to Section TOC
Return to Master TOC

Return to Section TOC
Return to Master TOC

Return to Section TOC
Return to Master TOC

Return to Section TOC
Return to Master TOC

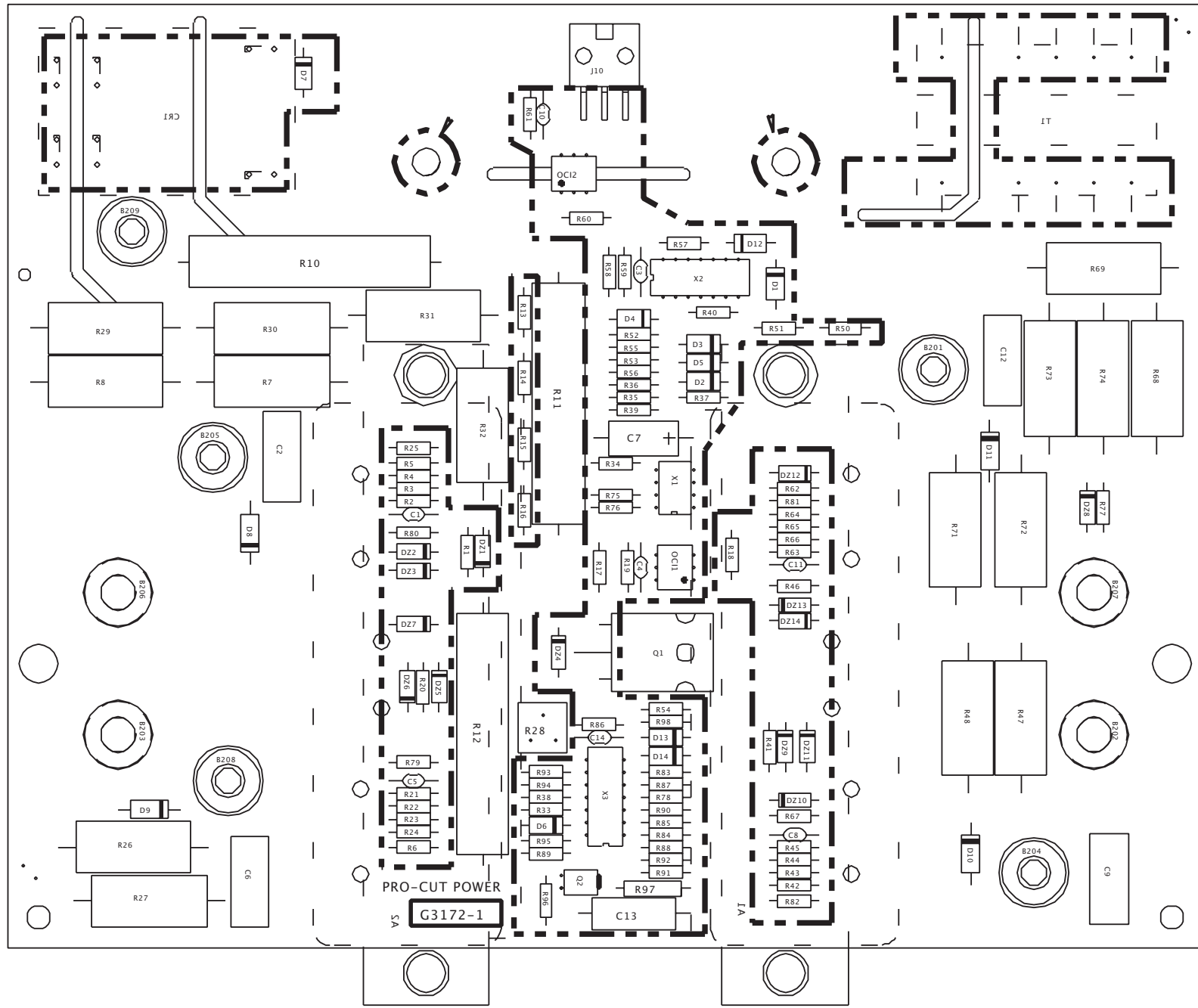

ITEM	REQ'D	PART NO	IDENTIFICATION
C1,C5,C8,C11	4	S16668-6	4700pF/50
C2,C6,C9,C12	4	S20500-4	.0047/1000V
C3,C4,C14	3	S16668-5	.022/50
C7	1	S13490-93	27/35
C10	1	S16668-9	150pF/100
C13	1	S13490-130	.27/50
CR1	1	S14293-18	DPST RELAY
D1,D2,D3,D4,D5,D6,D7,D12 D13,D14	10	T12199-1	1N4004
D8,D9,D10,D11	4	T12705-44	DIODE 1000V/1A
DZ1,DZ5,DZ9,DZ12	4	T12702-40	1N4735
DZ2,DZ3,DZ6,DZ7,DZ8,DZ10 DZ11,DZ13,DZ14	9	T12702-29	1N4744A
DZ4	1	T12702-19	1N4742A
J10	1	S20351-6	HEADER
OC11,OC12	2	S15000-22	OPTO ISOLATOR
Q1	1	T12704-75	FET (SS)
Q2	1	T12704-73	IC PKG MOSFET (SS)
R1,R6,R20,R25,R41,R46,R62 R67,R79,R80,R81,R82	12	S19400-10R0	10 1/4W
R2,R3,R4,R5,R21,R22,R23 R24,R42,R43,R44,R45,R60 R63, R64,R65,R66	17	S19400-1001	1K 1/4W
R7,R8,R26,R27,R47,R48,R68 R69	8	T14648-21	2.7 OHM 5W
R10,R11,R12	3	T14649-4	100 10W
R13,R14,R15,R16,R34,R35 R50,R51,R83,R86	10	S19400-1503	150K 1/4W
R17	1	S19400-1000	100 1/4W
R18,R77	2	S19400-1821	1.82K 1/4W
R19	1	S19400-2673	267K 1/4W
R28	1	T10812-41	10K 1/2W TRIMMER
R29,R30,R31,R32,R71,R72 R73,R74	8	T14648-12	1500 OHM 5 WATT RESISTOR
R33,R38,R58	3	S19400-3321	3.32K 1/4W
R36,R52,R89,R90	4	S19400-6191	6.19K 1/4W
R37,R55,R91,R92	4	S19400-1502	15K 1/4W
R39,R53	2	S19400-1652	16.5K 1/4W
R40,R56,R84,R87	4	S19400-3323	332K 1/4W
R54	1	S19400-1372	13.7K 1/4W
R57,R59,R85,R88	4	S19400-1002	10K 1/4W
R61	1	S19400-2213	221K 1/4W
R75	1	S19400-5620	562 1/4W
R76,R98	2	S19400-2801	2.8K 1/4W
R78	1	S19400-2001	2.0K 1/4W
R93	1	S19400-4751	4.75K
R94	1	S19400-4752	47.5K 1/4W
R95,R96	2	S19400-2211	2.21K 1/4W
R97	1	T12300-79	1 WATT 1 OHM 1% RESISTOR
T1	1	S13000-46	TRANSFORMER
X1	1	S15128-10	VOLTAGE REF.
X2	1	S15128-4	LM224 OP-AMP
X3	1	S15128-18	QUAD-OP AMP

NOTE: Lincoln Electric assumes no responsibility for liabilities resulting from board level troubleshooting. PC Board repairs will invalidate your factory warranty. **Individual Printed Circuit Board Components are not available from Lincoln Electric.** This information is provided for reference only. Lincoln Electric discourages board level troubleshooting and repair since it may compromise the quality of the design and may result in danger to the Machine Operator or Technician. Improper PC board repairs could result in damage to the machine.



PC BOARD ASSEMBLY-POWER (G3172-2)

Return to Section TOC
Return to Master TOC

Return to Section TOC
Return to Master TOC

Return to Section TOC
Return to Master TOC

Return to Section TOC
Return to Master TOC

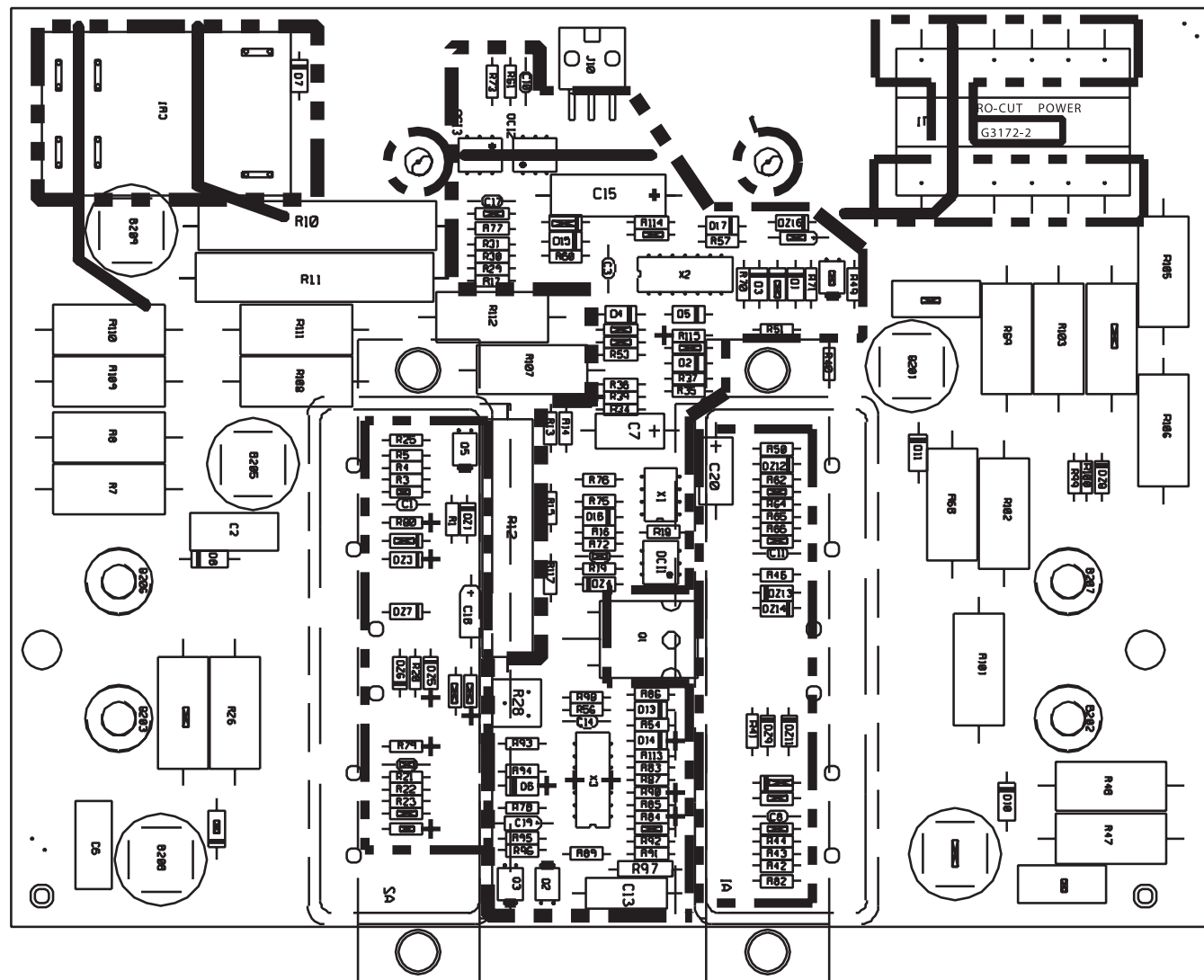

ITEM	REQ'D	PART NO	IDENTIFICATION
C 1, C 5, C 8, C 11	4	S16668-6	4700pF/50
C 2, C 6, C 9, C 12	4	S20500-4	.0047/1000V
C 3, C 14	2	S16668-5	.022/50
C 4, C 10, C 17	3	S16668-9	150pF/100
C 7, C 20	2	S13490-93	27/35
C 13	1	S13490-130	.27/50
C 15	1	S13490-83	50/25V
C 16, C 19	2	S13490-42	1.0/35
C 18	1	S13490-39	18/15
CR 1	1	S14293-18	DPST RELAY
D 1, D 2, D 3, D 4, D 5, D 6, D 7, D 12 D 13, D 14, D 15, D 16, D 17	13	T 12199-1	1N4004
D 8, D 9, D 10, D 11	4	T 12705-44	DIODE 1000V/1A
DZ 1, DZ 5, DZ 9, DZ 12	4	T 12702-40	1N4735
DZ 2, DZ 3, DZ 6, DZ 7, DZ 8, DZ 10 DZ 11, DZ 13, DZ 14	9	T 12702-29	1N4744A
DZ 4, DZ 15	2	T 12702-19	1N4742A
DZ 16	1	T 12702-52	1N4733A
J 10	1	S20351-6	HEADER
OCI 1, OCI 2, OCI 3	3	S15000-22	OPTO ISOLATOR
Q 1	1	T 12704-75	FET (SS)
Q 2, Q 3, Q 4, Q 5	4	T 12704-73	IC PKG MOSFET (SS)
R 1, R 6, R 20, R 25, R 41, R 46, R 62 R 67, R 79, R 80, R 81, R 82	12	S19400-10R0	10 1/4W
R 2, R 3, R 4, R 5, R 18, R 21, R 22 R 23, R 24, R 42, R 43, R 44, R 45 R 60, R 63, R 64, R 65, R 66, R 73 R 99, R 100	21	S19400-1001	1K 1/4W
R 7, R 8, R 26, R 27, R 47, R 48, R 68 R 69	8	T 14648-21	2.7 5W
R 10, R 11, R 12	3	S24376-3	100/10W
R 13, R 14, R 15, R 16, R 34, R 35 R 50, R 51, R 83, R 86	10	S19400-1503	150K 1/4W
R 17, R 19, R 29, R 30, R 31, R 40 R 49, R 61, R 74	9	S19400-2213	22K 1/4W
R 28	1	T 10812-41	10K 1/2W TRIMMER
R 32, R 71, R 98	3	S19400-2212	22.1K 1/4W
R 33, R 38	2	S19400-3321	3.32K 1/4W
R 36, R 52, R 89, R 90	4	S19400-6191	6.19K 1/4W
R 37, R 55, R 93	3	S19400-7681	7.68K 1/4W
R 39, R 53, R 57, R 70, R 85	5	S19400-1002	10K 1/4W
R 54	1	S19400-1372	13.7K 1/4W
R 56	1	S19400-2941	2.94K 1/4W
R 72	1	S19400-1000	100 1/4W
R 75	1	S19400-5620	562 1/4W
R 76	1	S19400-2801	2.8K 1/4W
R 77	1	S19400-4751	4.75K
R 78	1	S19400-1822	18.2K 1/4W
R 84, R 87	2	S19400-3323	332K 1/4W
R 88	1	S19400-1652	16.5K 1/4W
R 91, R 92	2	S19400-1502	15K 1/4W
R 94	1	S19400-4752	47.5K 1/4W
R 95, R 96	2	S19400-2211	2.2K 1/4W
R 97	1	T 12300-79	1 WATT 1 OHM 1% RESISTOR
R 101, R 102, R 103, R 104, R 105 R 106, R 107, R 108, R 109, R 110 R 111, R 112	12	T 14648-19	1K 5W
R 113	1	S19400-1821	1.82K 1/4W
R 114, R 115, R 116, R 117	4	S19400-1004	1M 1/4W
T 1	1	S13000-46	TRANSFORMER
X 1	1	S15128-10	IC, 431, VOLTAGE REF.
X 2, X 3	2	S15128-4	IC, LM224, OP-AMP

NOTE: Lincoln Electric assumes no responsibility for liabilities resulting from board level troubleshooting. PC Board repairs will invalidate your factory warranty. **Individual Printed Circuit Board Components are not available from Lincoln Electric.** This information is provided for reference only. Lincoln Electric discourages board level troubleshooting and repair since it may compromise the quality of the design and may result in danger to the Machine Operator or Technician. Improper PC board repairs could result in damage to the machine.



